

Vianti Falls Kit



Installation Manual

Thank you for your purchase of the Vianti Falls system from EasyPro. Please read through all instructions before beginning assembly of your Vianti Falls system. Be sure that all components are included before assembly.

Vianti Falls Kit Parts List	HB23K, HB23KB, HB23KW (EX)	HB35K, HB35KB, HB35KW (EX)
	Quantity	Quantity
48" Curved Basin (48" x 24" x 15 1/2"h)	1	1
Vianti Falls Spillway (standard or extended lip)	1-SSS23 or 1-SSS623 (single inlets)	1-SSS35 or 1-SSS635 (dual inlets)
Pump	1 – EP1350 (3 yr. warranty, 20' cord)	1 – EP2200 (3 yr. warranty, 26' cord)
LED Light (15' cord) with 10 watt transformer	HB23K(EX) - no light HB23KB(EX) - LED23CB - blue light HB23KW(EX) - LED23W - warm white light	HB35K(EX) - no light HB35KB(EX) - LED35CB - blue light HB35KW(EX) - LED35W - warm white light
1" Flexible black PVC pipe	8'	10'
Pump discharge assembly with ball valve	1	1
PVC Glue – 4 oz	1	1
1" PVC male adaptor (mpt x slip)	2 (1 extra)	3 (1 extra)
1" PVC Tee (slip x slip x slip)		1
1" PVC 90 deg elbow (slip x slip)	2 (1 extra)	3 (1 extra)
14" x 39" Splash Mat for EX kits only	1 (EX kits only)	1 (EX kits only)

Vianti Falls kits come with some fittings installed already in the basin. Installed fittings include: one 1" bulkhead fitting, one 1" rubber coupling, one 1" PVC 45 degree elbow, and two 1" male fitting adaptor (mpt x spigot)



Mag Drive Pump



Basin
(standard or extended splash mat)



Spillway
(23" or 35" standard or extended lip)



LED Light Strip with Transformer



1" 90° PVC Elbow



1" PVC Tee



PVC Male
Adapter



Pump Discharge
Assembly



Flexible PVC

Some items may vary in appearance from photos above due to kit variations

1 Determine the placement of the Vianti Falls system. Prepare the base for the 48" half basin by properly compacting and leveling the area. The Vianti Falls spillway is designed to be placed approximately 12" to 30" above the basin. The center of the spillway and the basin must be aligned. The spillway must be positioned in the wall to allow for the lip to protrude past the wall 1 1/4" (assuming the wall is plumb). This is to ensure water will land in the 6" x 39" splash mat included with the basin. Extended lip kits come with 14" x 39" additional splash mat to be installed on top of basin (see page one).

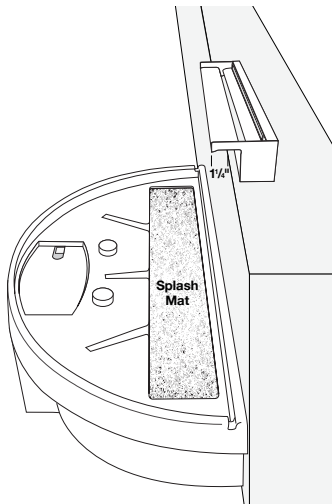

2 When building the block wall, a section of wall must be left out to accommodate the plumbing and electrical cord for the pump. The notch in the back of the basin is for the power cord of the pump. If an auto fill line is being installed a section of wall should also be open to accommodate the auto fill feed line.

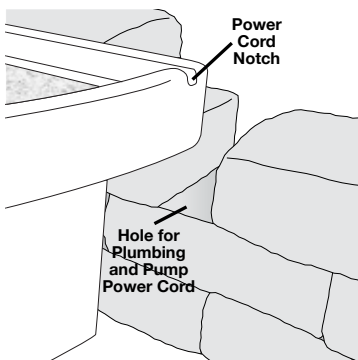

3 Once the spillway placement has been determined in the block wall, the block will need to be cut to allow for the plumbing connections on the back of the spillway. Use appropriate tools and extreme care when cutting block. Consult block manufacturer recommendations for properly cutting block being used.

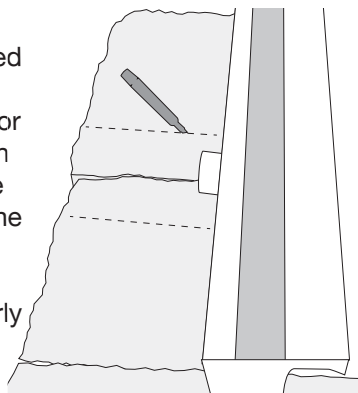

4 If the lighting option is purchased the LED light strip can be fitted into the back of the spillway. There are brackets on the ends of the light bars with holes in them. These brackets are for other applications. The LED light bar should fit snugly into the back of the spillway. If necessary, a small amount of silicone can be used as an adhesive to hold the bar in place.

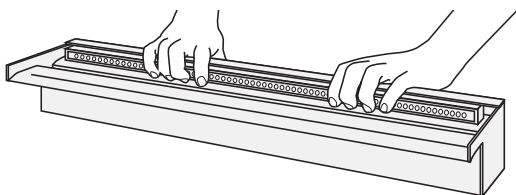

5 Depending on the look desired, the block that goes around the spillway may need to be cut to ensure proper leveling and look of the spillway in the wall. The type of block being used will determine the method used. A lenticular may be required for longer spillways or in walls that would require additional weight bearing support. Consult a qualified professional for specific installation requirements and codes. The spillway should be "dry fit" to ensure the spillway is level from side to side and front to back.

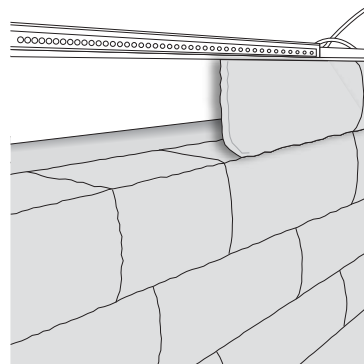

6 Once the spillway is level and "dry fit" the plumbing can now be fitted. Use the 1" PVC male adaptor and the fittings provided to connect spillway to the flexible PVC pipe. Wrap the threads of the PVC male adaptor with Teflon tape and thread into the spillway inlet(s). Determine the placement of additional fittings (elbows, tees, and extra pipe). Cut and glue all the pieces together to fit the application.

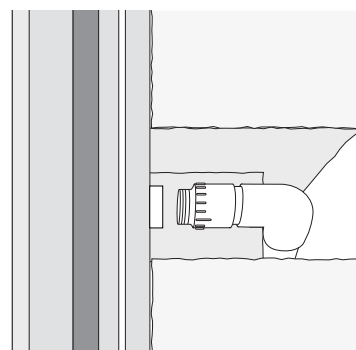

7 The dual inlet units can be supplied with one mainline. Picture is for illustration only. Application may vary from image shown. After the mainline is split into two, the plumbing lengths to the spillway inlets should be equal. This will ensure equal flow rates to both inlets, while being able to control the overall flow with a single ball valve.

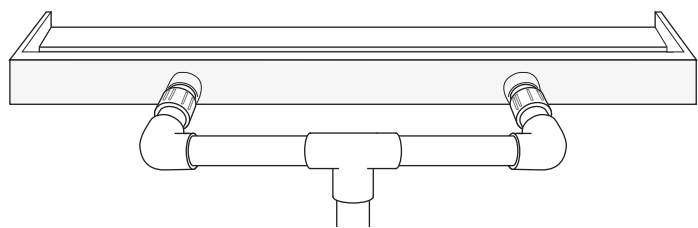

8 The cord for the LED light strip can be tucked into the notch in the spillway. A dab of silicone should be used to seal the notch on opposing side. Tuck the cord between the blocks to run the cord to the power source. Ideally, run cord through conduit for future maintenance or removal of light strip.

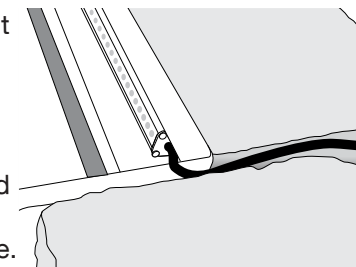

Optional: Steps 9-11 are for auto fill installation. Not all applications may need an auto fill, autofill kit #WFS37HB available.

9 Find the "Drill Point" mark on the front of the basin. The point/indent will be on the opposite side of the pump pocket from the installed 1" bulkhead fitting. A 1 1/4" diameter hole should be drilled (centered on the "Drill Point") to accommodate the 1/2" bulkhead fitting.

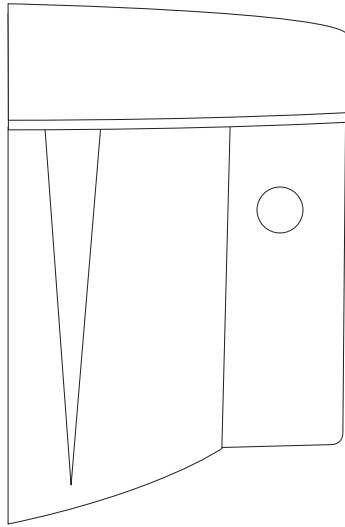

10 Install the 1/2" bulkhead fitting as shown. Wrap male threads of fittings with Teflon tape. Install elbow into bulkhead fitting and thread the reducer bushing into elbow. Thread the barbed fitting into outer section of bulkhead to connect to 1/2" poly irrigation tubing (actual 5/8" ID tubing).

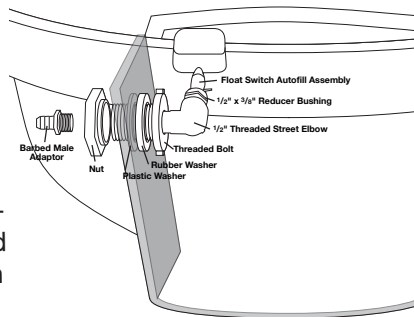

11 Before installing the float switch auto fill, loosen the Phillips screw to place float in proper orientation. It may be necessary to remove the screw and move the brass arm which holds the float to the side as shown. This will allow for easier adjustment of the float to proper water level. Then thread the float switch assembly into the reducer bushing. Adjust the brass rod and float to approximate level of desired water level. Final adjustment should be made when final water level is determined.

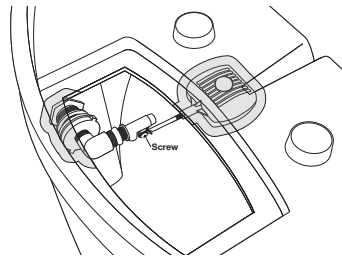

12 Run the 1" black flexible PVC through the hole previously provided in the block wall. Carefully measure and cut PVC pipe to proper length. Take extra care to verify the spillway has remained in its level position while measuring and cutting the pipe.

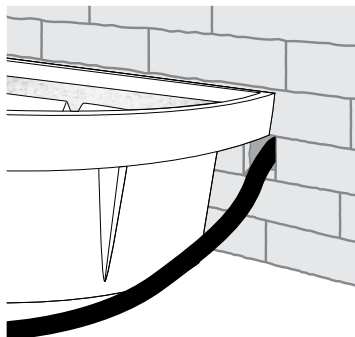

13 Before gluing black flexible PVC pipe verify the factory installed fittings are tight. Then glue the black flexible PVC pipe into the 45 degree elbow that is pre-installed.

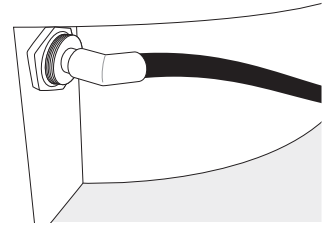

14 Assemble the pump discharge assembly onto the pump. Take care not to cross thread or over tighten the assembly onto the pump. Since this connection should always be below water, Teflon tape and over tightening is not required. Once the discharge assembly is installed onto the pump, carefully lower the pump and assembly into the pump chamber. Line up the pump discharge with the pre-installed fitting. Again ensure that the pre-installed fitting is tight. Connect the pump discharge to the pre-installed fitting with the rubber coupler. A nut driver or screwdriver should be used to tighten the clamps. Ensure that both clamps are tight.

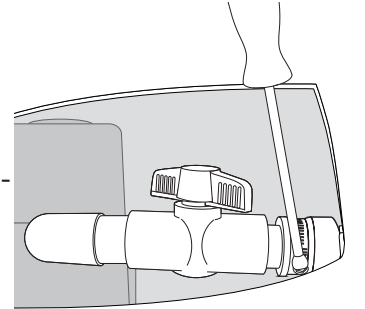

15 After making sure all plumbing fittings are properly installed, fill the basin with water. The spillway should be tested for proper operation when the wall construction allows. Before final wall installation and covering the basin with rock, the proper flow of the water fall should be adjusted (if needed) with the ball valve on the pump discharge assembly.

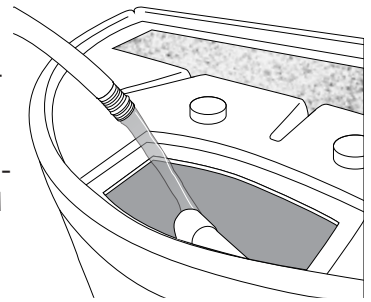

16 Once proper adjustment of the spillway has been determined, put the pump cover in place. The power cord for the pump can run through the notch in the pump cover. The pump cover can be placed in position as shown or reversed.

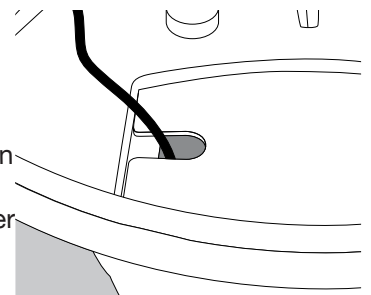

17 Finish construction of the block wall and any other decorative stone covering the basin. Be sure to leave rock off the area of the splash mat on the basin where the water naturally wants to fall. This will reduce splash and help retain water in the basin.



Care:

The water used in the Vianti Falls system can be treated with EasyPro All-Season Bacteria and EasyPro Barley Straw Extract to help prevent odors and keep the water clear. A liquid algaecide such as Pond Care's Algae Fix or Microbe-Lift's Algaway 5.4 can also be used. Use of chlorine is not recommended, as this may have negative impact on the submersible pump parts.

If water flow appears to be less than normal, water may need to be added to the basin (bubbles in the waterfall typically indicate low water in the basin). A physical inspection of the pump may be necessary. Clean off any debris that may have accumulated on the pump housing or inside the pump. Consult instructions of pump for more information.

While staining on the spillway should not be an issue, a light abrasive cleaning pad can remove many stains or discolorations that occur.

Should the splash mat need to be replaced, contact your local EasyPro dealer to purchase replacement part #FWB48M (6" x 39" mat) or part #FWB48SM (14" x 39" mat).

Winterization:

In freezing climates the pump will need to be removed from the basin in the winter. The roto-molded basin typically does not need to be drained completely in the winter, but in certain climates this may be recommended.

The water level in the basin should be lowered below the outgoing bulkhead fitting.

The stainless steel spillway does not need to be removed for the winter. Water naturally drains from the spillway when the pump is not in use.

Auto-fill systems should be properly winterized.

Limited Warranty Information:

Basin – Ten year limited warranty (covers tub only, not splash mat, pump cover or additional fittings pre-installed)

Vianti Falls stainless steel spillway – Three year limited warranty

LED light strip – Three year limited warranty

Pump – Three year limited warranty (see pump owners manual for details)

- This product is warranted against any mechanical or material defects from the date of purchase.
- This limited warranty does not cover accidental damage to the product due to abuse or negligence by the consumer.
- **An RMA number must be obtained by calling EasyPro Pond Products at 800-448-3873 and be included on package before returning for warranty issues.**

Return warranty items to:

EasyPro Pond Products, 4385 East 110th, Grant, MI 49327

Be sure to include RMA number, original receipt, name, return address and phone number in package.

- In the event of a warranty claim, please return the product postage prepaid with the original receipt for repair or exchange. No warranty claims will be honored without the original receipt.
- The manufacturer or supplier shall not be held liable for any damages caused by defective components or materials of this product; or for loss incurred because of the interruption of service; or any consequential/incidental damages and expenses arising from the production, sale, use or misuse of this product.



800-448-3873 • Grant, Michigan
www.easypropondproducts.com • info@easypropondproducts.com