

### Features

- This high performance, medium head pump comes complete with an industry standard Carbon/Ceramic  $\frac{5}{8}$ " mechanical seal for convenient replacement.
- Pump parts are made of 100% recyclable plastic. Non-corrosive, chemical/UV resistant, and can withstand temperatures of up to 150° F.
- Discharge on the GV100 and GV150 can be rotated.
- Suction and discharge ports are equipped with 1½" SLIP ABS unions.
- Specially constructed clear lid with ring lock design is easy to open. Large strainer basket is always locked in place.
- Pump is equipped with durable, economical 48 frame throbolt mount motor with stainless steel shaft.
- Pump has a standard 6 ft. cord set pre-mounted.
- Reusable o-rings throughout.
- GV100 and GV150 come complete with one year warranty.
- Every pump is performance tested before leaving the factory.



GV150



### Applications

- Water gardens
- Koi ponds
- Water features
- Fountains

### Dimensional Drawings

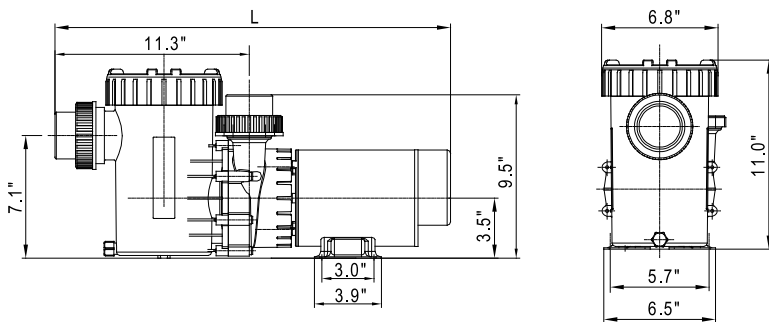

### Performance Curves

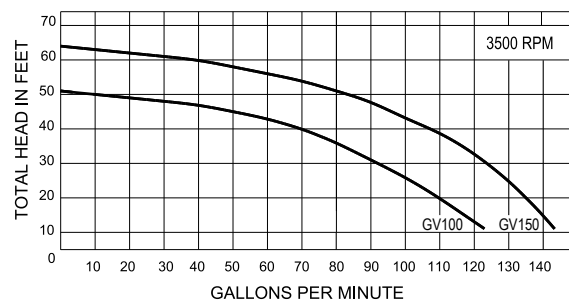

### Specifications

PART #	HP	AMPS	VOLTS	LENGTH (DIMENSION L)	MAXIMUM HEAD	SHIP WEIGHT
GV100	1	12	115	21½"	51'	33 lbs.
GV150	1.5	16	115	23"	62'	34 lbs.

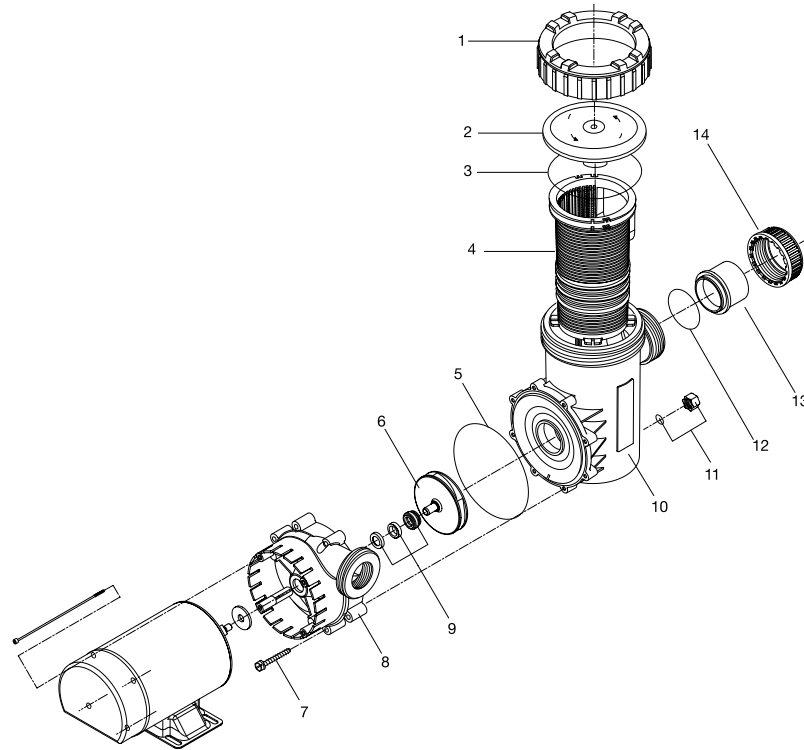

DRAWING NUMBER	QTY. REQUIRED	DESCRIPTION
1	1	Lock Ring Lid
2	1	Lid - Clear
3	1	O-Ring - Lid 137 x 5mm
4	1	Basket - One Piece
5	1	O-Ring Casing 144 x 4mm
6.1	1	Impeller 1.0 THP (1.5 HP SPL) 98/9mm
6.2	1	Impeller 1.5 THP (2.0 HP SPL) 106/9mm w/insert
7	8	Screw - Casing. Hex/Washer/Slot M7 x 48mm
8	1	Casing
9	1	Mechanical Seal ( $\frac{5}{8}$ " ) - Carbon/Ceramic
10	1	Strainer Tank
11	1	Drain Cap $\frac{3}{8}$ " with Gasket - Casing
12-14	1	Union Package ( $1\frac{1}{2}$ " ) SLIP Complete - Suction/Discharge