

Aquadyne “RHINO II” Bottom Drain Installation Instructions

Manufactured by Aquadyne/Crane Enterprises Inc.

Congratulations on the purchase of your new Rhino bottom drain.

In this installation guide, you will find easy to follow steps to install your new bottom drain.

Please Read All Information before Installing the Drain.

This drain has been designed to make installations easy, with a dependable seal to protect against hidden leaks, which can happen with most other drain flanges available today.

By having a wider machined flange, Rhino also allows for a greater margin of error by the installer when cutting the liner to fit the drain. Please follow the installation guide as closely as possible. Typically there are no shortcuts to a good dependable installation.

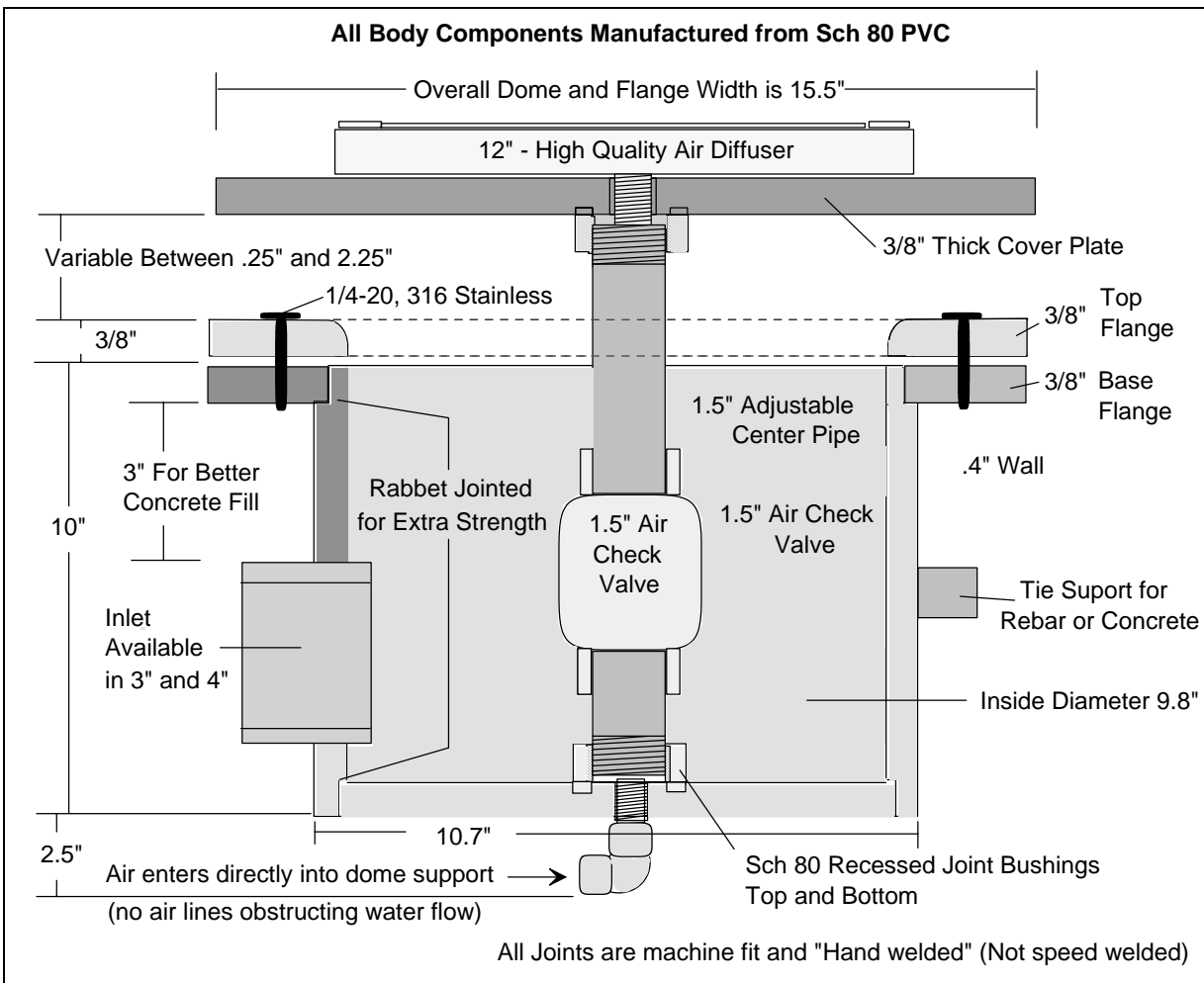

Thank You For Putting a “ RHINO ” In Your Pond!

Rhino I - Installation

Step 1 Typical Installation - Liner

After shaping your pond bottom to the desired contour. Locate where your bottom drain is to be installed and dig out an area approximately 16 to 22 inches wide and 14 to 18 inches deep. Then excavate a trench away from the drain location wide enough to accommodate the drain pipe. The trench should be deep enough so that the top of the base flange is level with the final grade of the pond bottom. Be aware that if the bottom of your pond has been backfilled with loose dirt, undesirable settling may occur unless the fill is firmly packed down.

Helpful Hint: Pre-assemble the bottom drain and the first section of pipe and air line and lay it into your trench as you dig. Remove enough dirt from the bottom of the drain basin so that there is at least three inches of space between the bottom of the drain and the ground. This will allow adequate space for a concrete foundation and will prevent settling of the drain.

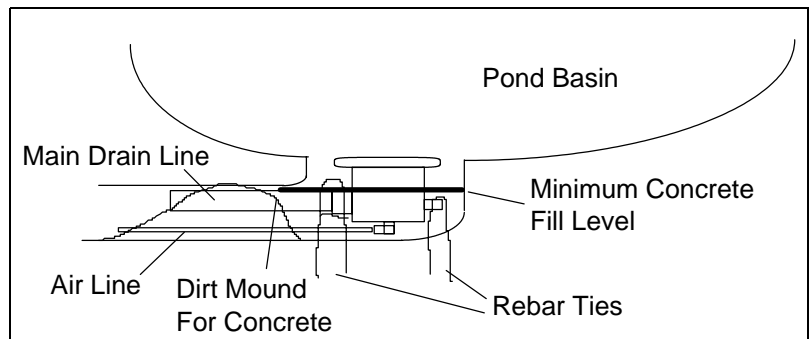

Step 1 Typical Installation - Concrete

The concrete foundation can also be filled to the top of the liner sealing flange if desired. If you fill with concrete to the minimum concrete fill level as indicated above. The remainder of fill to the flange must be compacted very tightly. Otherwise unsightly settling will occur once the pressure of the water is applied to the liner. And you will have a depressed ring around the drain flange. Complete concrete fill is recommended.

When installing a Rhino II in a concrete pond, anchor the drain with rebar as indicated in the above drawing so that the flange plate is at the proposed finish level of the inner surface of the pond basin once the concrete is added and not level with the unfinished dirt bottom. When constructing a concrete pond, it is not necessary to use the liner binding plate and screws. But leaving them attached will not affect the installation. Simply tighten the screws first.

This Will Complete The Installation For Concrete.

If you are installing in dirt, proceed to the next step.

Step 1 Typical Installation - Liner Continued

Take a 3' x 3" piece of plastic or a large garbage bag and cut a 10" hole in the center. Slip the hole over the bottom flange of the drain and tie a string or other strap around the pipe gathering the plastic under the flange. Bunch the plastic over the flange to keep dirt and debris from getting onto the flange surface while backfilling if using dirt. **Helpful Hint:** Stick small pieces of masking or duct tape over the screw holes in the flange plate to prevent dirt, concrete or any other debris from getting in the holes, and remove the tape just before adding the adhesive to the flange plate. If you are backfilling around the flange with dirt, add about 2" of dirt at a time while packing. Pack the dirt firmly flush to the top level of the flange. Concrete is still recommended rather than dirt.

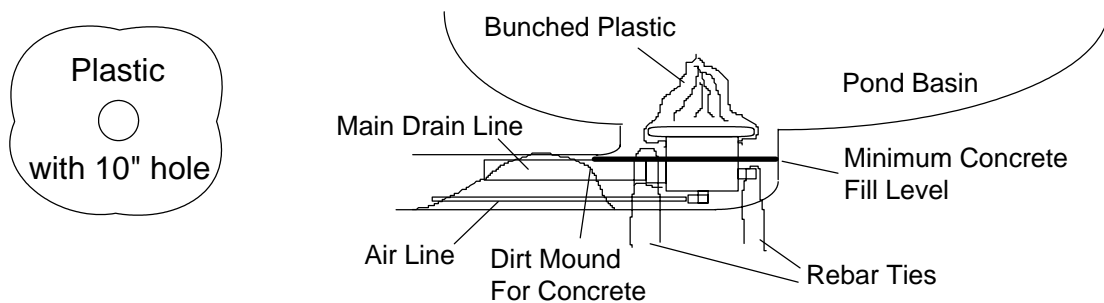

Step 2 (Option) Rather than using dirt to pack around the flange and pipe to restore the integrity of the pond bottom around the flange, again., you can use concrete just as effectively. Although a bit more trouble initially, concrete is very effective. It will not compress once water is added to the pond. When using concrete, excavate about 16" to 18" width for the drain placement rather than 12". Also, finish with the flange plate and concrete about 3/8" below the dirt level of the pond bottom. This will allow for any settling of the existing dirt bottom under the weight of water to finish out at the poured concrete level.

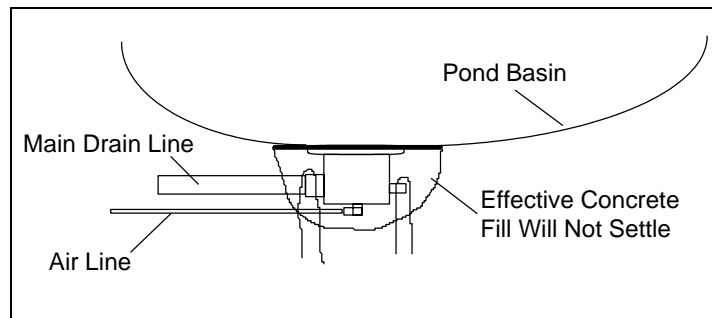

The remainder of these instructions are for installations that are backfilled with dirt.

This next sections diagrams are for a smaller flanged drain, but all of the directions are appropriate, so follow the directions as indicated.

Step 3 Typical Installation - Liner

Unbunch the plastic from over the drain and flatten it out all around the drain to cover the surrounding dirt or concrete fill. This will give you a very clean working area when applying adhesive to flangeplate. Now you can lay your liner protection fabric and liner into your pond basin.

Step 4 Typical Installation - Liner Protection Fabric

Install your liner protection fabric to cover the entire inner surface of the pond bottom. Cut a hole in the liner protection fabric that will allow the fabric to lay evenly around the flange without touching the flange. If the fabric is not cut back from the flange at least 1/2", the fabric could get caught between the flange plates on final assembly and result in bad seal.

Step 5 Typical Installation - Liner Preparation and Alignment

Drape the liner into the prepared pond bottom over the bottom drain flange, adjusting it into its final position. Make sure that there is sufficient overlap on each pond edge to assure proper water level and containment of water. Once everything is in position, step into the pond onto the liner. Remove your shoes to protect the liner. An ounce of prevention will save you many tears. Locate the bottom drain flange. The following steps are very easy, but exercise care.

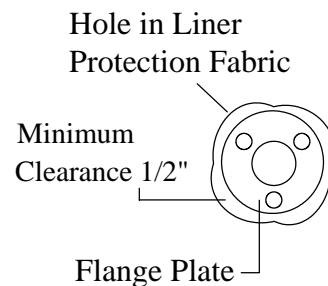

- A. Depress the liner in the center of the bottom drain flange until you can see the pipe contour.
- B. With a marker draw a ring around the pipe contour. You will be able to distinguish the ring even though the marker will likely be black.
- C. With a sharp knife or scissors, cut out the center of the circle and remove it. If your liner hole is slightly larger than the hole itself, do not worry, because the sealing area of the flange is quite large, however, try to keep the liner hole as near the same size as the drain hole.
- D. Once your liner hole is cut, lift the liner slightly and reach through the liner hole and remove the tape that you placed over each screw hole in the Step 2 Helpful Hint.
- E. Once the tape is removed, lay the liner back on the base flange with the center hole reasonably aligned and press around on the liner over the flange and locate the 6 screw holes.
With a felt tip pen mark the center of each of the holes. Do not let the liner move or the marks will not align properly. Here again, the Rhino flange is larger than any other drain

flange on the market today, which allows for a greater margin of error, so don't stress out about absolutely perfect alignment, or perfectly round bolt holes.

- F. Once the bolt holes are marked, cut or punch an approximate 1/4" hole at each of the 6 marks. You can pinch the liner and cut the holes by using wire cutters, making a small V snip, or use a leather hole punch. Make the hole slightly larger than the bolt diameter. This will allow any trapped air pockets created by the adhesive to escape through the liner and binding plate when tightening the bolts. A hole is a hole, just keep it reasonably on center.
- G. Before applying any adhesive, align the liner over the base flange and place the top binding plate on top of the liner over the holes in the base flange. Insert the 6 stainless binding screws into each of the 6 holes and dry fit the assembly together. Once you have a good fit, remove the screws and binding plate.
- H. With a degreasing household cleanser such as 409, Simple Green, Orange Clean, etc., clean both sides of the liner where adhesive is to be applied. Use a terry cloth or other strong rag so that you can scrub the surfaces of the liner to be glued. These surfaces need to be scrubbed to remove any release agent used to manufacture the liner. Adhesives do not stick to release agents very well. Use a wet rag with clean water to rinse the surfaces once cleaned. Typically the sealing surfaces of the flanges will not need to be cleaned unless they have become soiled once removed from the factory box.

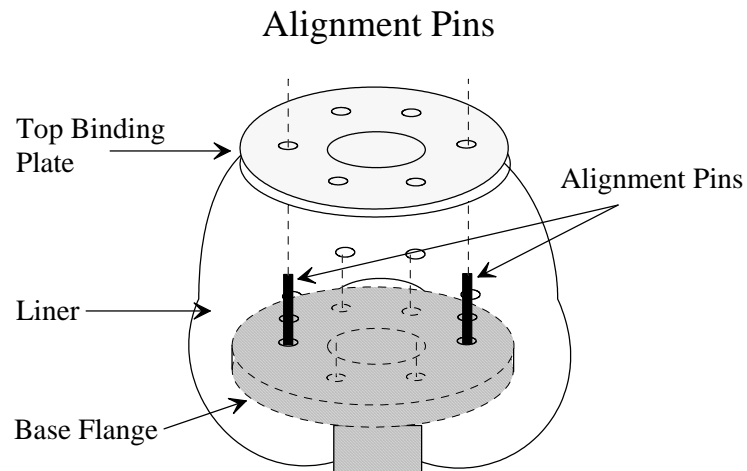

Step 6 Typical Installation - Liner - Applying the Adhesive

Adhesive selection: Any high grade silicone is suitable for securing a leak-proof seal of the bottom drain to a liner. Through experimentation with various materials we have found that a

P
r
o
d
u
c
t
k
n
o

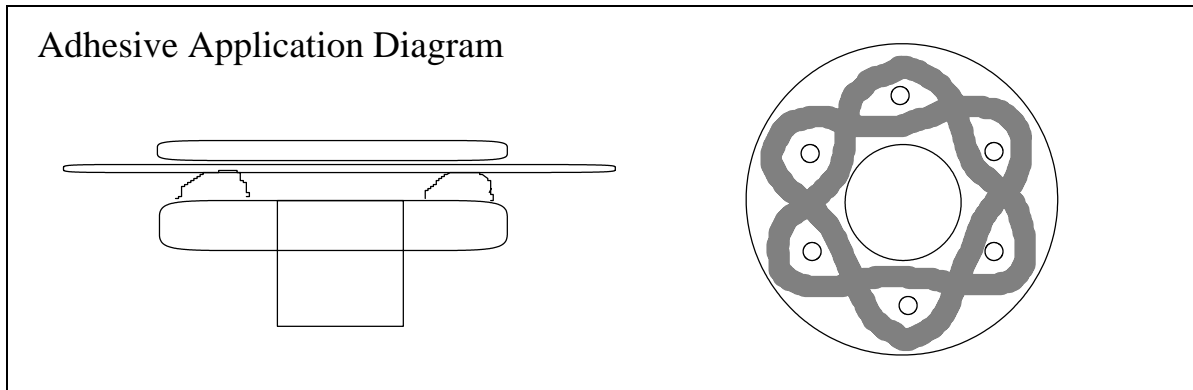

wn as LEXEL is an extremely dependable inexpensive adhesive for underwater applications such as drains.

- A. Lift the liner off of the base flange just enough to insert a tube of adhesive through the hole and squeeze the adhesive onto the base flange in the pattern shown in the “Adhesive Application Pattern” diagram. Use about a 1/2” wide generous thick bead of adhesive. Adhesive is only required on the base flange under the liner. When applying the adhesive weave in and out of the bolt holes taking care not to get the adhesive into the bolt holes. Make a second pass with the adhesive weaving in and out of the bolt holes on the opposite sides of the holes on the original pass. ie: You will have a connecting bead of adhesive around each hole with this pattern. (see adhesive application diagram) DO NOT use concentric circles of adhesive on the inside and outside of the bolt holes. Multiple circular beads will trap air when squeezed and cause an adhesive blow out, and your liner will not seal properly. Again, DO NOT get the adhesive in the screw holes. The holes have solid bottoms and do not need adhesive. If you get adhesive in the screw holes, the screws may not screw in completely. **“If By Chance”**, you get a screw hole that gets full of adhesive and the screw will not fully screw in, the best bet is to remove the screw, and drill a 1/16” hole in the bottom of the screw hole completely through the base flange to relieve the adhesive from the flange once the screw is reinstalled. There is no need to fear a leak in this case because the adhesive in the

screw hole will self seal the threads against a leak. This is a much better solution than trying to clean out the adhesive. You are halfway through the adhesive installation by this point and trying to clean out the hole will create a bigger mess than it will resolve. Most adhesives do not set up for at least 30 minutes, so relax and go slow, there is no need to be in a hurry.

B. Now place the two alignment pins in any two screw holes directly across from each other in the base flange and allow the two corresponding liner holes to slip over the alignment pins. (see alignment pin diagram)

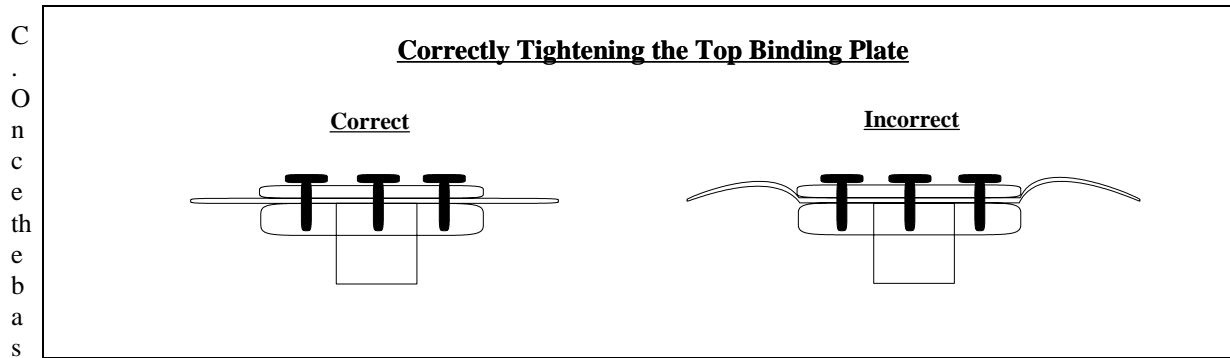

flange bead of adhesive is applied and the liner is gently in place, Gently place the “Top Binding Plate” in any position over the alignment pins (see alignment pin diagram) and let it “rest” on top of the liner. DO NOT press the binding plate down until all bolts are started in their bolt holes. No adhesive is required between the top binding plate and the top of the liner, however, you can put a thin film of adhesive in this area if you desire. Again, **DO NOT** mash the plate down. If you mash the plate down before installing the bolts, you will fill the screw holes with adhesive!

D. Insert 4 screws into the 4 open holes in the “Top Binding Plate” and hand thread them through the liner and into the base flange. Do not tighten yet. Remove the two alignment pins and screw the remaining two screws into the alignment pin screw holes. Now, tighten the screws in a criss cross pattern until the adhesive begins to ooze from between the liner and the base flange. Do not try to completely tighten down the screws. Once you notice the liner beginning to form a slight bulge around the top binding plate, **STOP!** If the liner bulges, the screws are too tight. Loosen each screw 1/8th turn each until the bulge relaxes.

When the binding plate bolts are correctly tightened, the liner does not bulge out around the binding plate. If the bolts are tightened too tightly, the liner will bulge out around the binding plate. If the liner does bulge from around the binding plate, loosen each bolt 1/8th turn until the bulge flattens out. A bulge is the result of the bolts being too tight and pinching the liner between the plates.

E. Your installation is complete! STOP, let the adhesive dry for 24 hours before adding water.

F. Before adding water to the pond, place the antivortex drain cover plate on top of the top binding plate and press the three posts of the cover into the receivers on the top binding plate. The two pieces should press together firmly in any position. To remove the antivortex cover, slide the fingers of both hands under the cover plate near the attachment posts and lift vertically with your finger tips. Lifting the cover plate from the edges will not allow the cover to slip free. This feature is by design so that fish can not inadvertently knock the cover off of the drain.

A note from the manufacturer:

We would personally like to thank you for choosing our products to aid you in the success of your pond. We are aware that this manual is quite long, however we felt it very necessary to include all of this information to aid you in your installation. We are aware of other installation guides for bottom drains that are simply a sheet with a single drawing and a few lines of instructions and felt that these one pagers quite often left the customer scratching their head as to what to do in a situation that could have so many different variables. We hope that this guide has been thorough enough so that your installation experience has been a positive one. If there is anything that you felt that was left out, or could make the installation more easily understandable, please give us a call or e-mail us at **koicamp@mindspring.com**. We would love to hear from you about your experience with our products!

Thank you for putting a RHINO in your pond!