



Regenair Regenerative Blowers



ISO 9001 Certified



Worldwide Excellence in Air Technology-

Smart Air Solutions for Your World

Regenerative Blowers

The Gast full line of Regenair® Regenerative Blowers for high volume vacuum or compressed air applications offers both motor-mounted and separate drive models. Air flow capabilities range from 27 to 1350 cfm (46 to 2294 m³/h), vacuum capabilities up to 183 in. H₂O (13.5 in. Hg/456 mbar), and pressure capabilities up to 284 in. H₂O (10.25 psig/707 mbar). TEFC electric motors are UL and CSA certified on several models and come in single and three-phase, dual frequency, and multi-voltage versions for worldwide applications; 12 volt DC is available on the smallest model. Horsepowers range from 1/8 to 30 HP (0,09 to 22,4 kW).

The explosion-proof motors series, designed primarily for soil vapor extraction operations, have air flow capacities up to 425 cfm (722 m³/h), with vacuum levels to 110 in. H₂O (8.1 in. Hg/274 mbar) and pressure capabilities up to 100 in. H₂O (3.6 psig/249 mbar). Motors range from 1/3 to 10 HP (0,25 to 7,5 kW). A complete line of recommended accessories for all blower series is also available.

- Complete line of blowers satisfies all single and three-phase motor requirements
- Low noise operation
- Continuous, non-pulsating, oil-free air flow
- Low maintenance
- Fan cooling dissipates heat around the bearings to help prolong bearing life
- Performance modifications and/or special requirements can be accommodated

The Regenerative Principle

In a regenerative blower, the compression space consists of a hollow, circular ring between the tips of the impeller blades and the walls of the housing. In operation, the rotating impeller draws in air from the inlet port into the compression space and moves it radially outward to the curved housing by centrifugal force.

The action is called “regenerative” because a certain amount of air slips past each impeller blade during rotation and returns to the base of a succeeding blade for reacceleration.

Because of this dynamic principle, regenerative blowers can generate pressure and vacuum performance comparable to many multi-stage or positive displacement blowers.

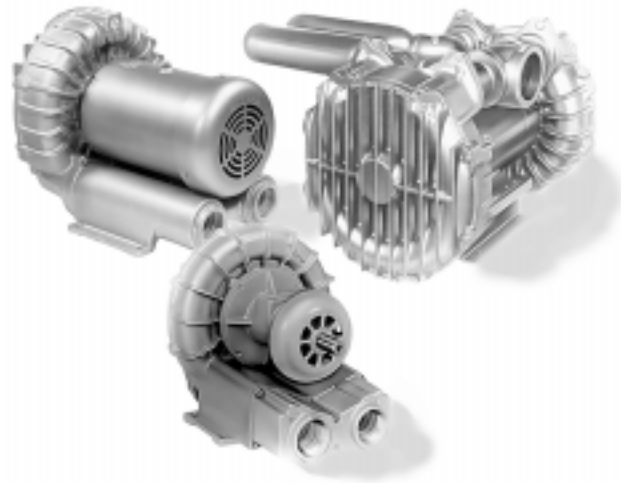

Regenair® Blower Features and Benefits

Standard Motor Mounted Models

- Rugged construction of cast aluminum or cast iron, depending on model size
- UL and CSA approved motors; TEFC on single-ended models, OPEN on dual-ended models
- Permanently sealed ball bearings incorporate new polyurea grease that extends bearing life and offers superior resistance to washout, rust and corrosion
- Integrated mufflers on single-ended models minimize operating noise

Explosion-Proof Motor Series

- UL and CSA approved explosion-proof multi-voltage motors with thermal protection
- Double sealed ball bearings with a B10 life exceeding 30,000 hours of continuous operation at the maximum rated continuous blower load
- Sealed air streams; leak tested to less than 5 cc/min

Separate Drive Series

- Drive pulley size can be changed to lower speeds and adjust performance
- Built-in acoustical muffling reduces operation noise
- Precision balanced impellers provide low vibration operation

Blower System Design Tips

In order to utilize your regenerative blower most efficiently, proper system design is essential. The most important thing to recognize is that by utilizing large diameter plumbing, friction losses in plumbing can be greatly reduced. Here are some guidelines to use when setting up your blower system:

1. The plumbing should at least be the same size as the blower port or ideally one size larger (example - blower has ports that are 1-1/2" NPT, plumbing should be 2" NPT). The plumbing should remain this size until it has reached the location of the work area.
2. Plumbing for Separate Drive Blowers operating above 3500 RPM should be at least one pipe size larger than the blower ports.
3. Elbows create additional friction which causes pressure loss and back pressure. Plumbing at least one pipe size larger than the blower pipe ports minimizes the friction loss they create.
4. The pressure/vacuum relief valve should be installed in a "T" which is at least one pipe size larger than that of the exhaust of the blower. To properly protect a large horsepower blower, set the relief value to limit the blowers duty to 5 in. H₂O below its continuous duty rating.
5. Operating the blowers at high altitude decreases their maximum pressure or vacuum duty rating. If this is a consideration, review the information on Fan Laws in the Application Engineering section of this catalog.
6. The exhaust air temperature of the blowers increases with increasing duty. At duties over 70 in. H₂O it is too hot for most plastic pipe. Metal pipe must be considered. To prevent danger of burns, access to these pipes should be limited, guarded or marked "Danger Hot."

Performance Data

The performance data shown in this catalog was determined under the following conditions:

- Line voltage @ 60 Hz. 230V or 460V for three-phase units. 115V or 230V for single-phase units.
- Line voltage @ 50Hz. 220V for three-phase or single-phase units.
- Units in a temperature stable condition.
- Delivery measurements made with output port throttled.
- Suction measurements made with input port throttled.
- Test Conditions: Inlet air density at 0.075 lbs. per cu.ft. [20°C (68°F), 29.92 in. Hg (14.7 PSIA)].
- Normal performance variations on the resistance curve within ± 10% of supplied data can be expected.

Pictorial and dimensional data is subject to change without notice.

The information presented in this catalog is based on technical data and test results of nominal units. It is believed to be accurate and is offered as an aid in the selection of Gast products. It is the user's responsibility to determine suitability of the product for intended use and the user assumes all risk and liability whatsoever in connection therewith.

Gast can also provide CE compliant blowers with BSP threads, as well as customized blowers for specific applications. Consult a Gast Representative/Distributor for more information.

Environmental and application conditions may affect advertised life.

Warning:

Models Without Explosion-Proof Motors Should Not Pump Combustible Gases or Be Used In Combustible Ambients



Table of Contents

The Regenerative Principle, Features and Benefits	2
System Design Tips	3
Performance Table	5
Performance Curves	6, 7, 8
Envelope Dimensions	9
Applications	10, 11
Standard Motor Mounted Models	12 - 41
High Pressure Motor Mounted Models	42 - 53
Models with Explosion Proof Motors	54 - 61
Separate Drive Models	62 - 65
Accessories	66 - 69
Application Engineering Information	70 - 79

Performance Table

MODEL/ SERIES	POWER RATING @ 60 Hz		FREE AIR FLOW				MAXIMUM PRESSURE				MAXIMUM VACUUM			
	hp	kW	cfm		m ³ /h		" H ₂ O		mbar		" H ₂ O		mbar	
			50 Hz	60 Hz	50 Hz	60 Hz	50 Hz	60 Hz	50 Hz	60 Hz	50 Hz	60 Hz	50 Hz	60 Hz
Standard Motor Mounted Models														
R1*	1/8	0,09	23	27	39	46	21	28.5	52	71	20	26.5	50	66
R2*	1/3, 1/2	0,25, 0,37	33	42	56	71	30	39	75	97	25	35	62	87
R3*	1/2	0,37	43-44	52-53	73-75	88-90	31-40	43-55	77-100	107-137	28-35	40-50	70-87	100-125
R4*	1	0,75	75	92	127	156	38	52	95	130	35	48	87	120
R4P*	1 1/2	1,1	110	127	187	216	50	65	125	162	45	60	112	149
R5*	2 1/2	1,86	133	160	226	272	50	65	125	162	47	60	117	149
R6*	2 1/2- 5	1,86- 3,73	180	207- 215	306	352- 365	40- 78	45- 105	100- 194	112- 262	50- 70	55- 88	125- 194	137- 262
R6P*	3 1/2- 5 1/2	2,6- 4,1	225- 245	265- 290	382- 416	450- 493	50- 85	30- 110	125- 212	75- 274	50- 85	35- 90	126- 212	87- 224
R6PP*	11	8,2	420	520	714	884	75	95	187	237	65	80	162	199
R7*	10	7,46	350	420	595	714	115	125	286	311	90	110	224	274
R7P*	18	13,4	666	795	1132	1351	90	105	284	262	85	95	212	237
R9*	15	11,3	585	680	994	1155	125	125	311	311	105	115	262	286
R9P*	30	22,4	1140	1350	1937	2294	110	125	274	311	100	110	249	274
High Pressure Motor Mounted Models														
R4H*	6	4,5	107	128	182	217	284	284	707	707	183	183	456	456
R6PS*	11	8,2	230	280	391	476	145	170	361	423	110	130	274	324
R7S*	18	13,4	350	420	595	714	170	200	423	498	130	150	324	374
R9S*	30	22,4	585	660	994	1121	208	222	518	553	142	149	354	371
Explosion Proof Motor Models														
R3105N-50	1/2	0,37	44	53	75	90	31	43	77	107	28	40	70	100
R4110N-50	1	0,75	74	92	126	156	38	51	95	127	35	48	87	120
R4310P-50	1	0,75	74	92	126	156	38	51	95	127	35	48	87	120
R4P115N-50	1 1/2	1,1	112	133	190	226	45	65	112	162	40	60	100	149
R5125Q-50	2	1,5	—	160	—	272	—	55	—	137	—	60	—	149
R5325R-50	2	1,5	133	160	226	272	50	65	125	162	47	65	117	162
R6130Q-50	3	2,2	180	215	306	365	75	60	187	149	65	70	162	174
R6340R-50	4	3,0	180	215	306	365	75	100	187	249	65	80	162	199
R6P155Q-50	5 1/2	4,1	235	280	399	476	80	95	199	237	65	85	162	212
R6P355R-50	6	4,5	232	280	394	476	80	100	199	249	65	85	162	212
R7100R-50	10	7,5	350	425	595	722	90	100	224	249	85	110	212	274
Separate Drive Models														
SDR4	4	3,0	147		250		110		274		90		224	
SDR5	10	7,5	240		408		152		379		120		299	
SDR6	15	11,2	300		510		155		386		135		336	

*Models equipped with UL and CSA certified motors. (except R1102K (12v DC))



Performance Curves - Low Range for Pressure/Vacuum

Motor mounted series R1, R2, R3, R4, R4P, R5

Performance at 60 Hz

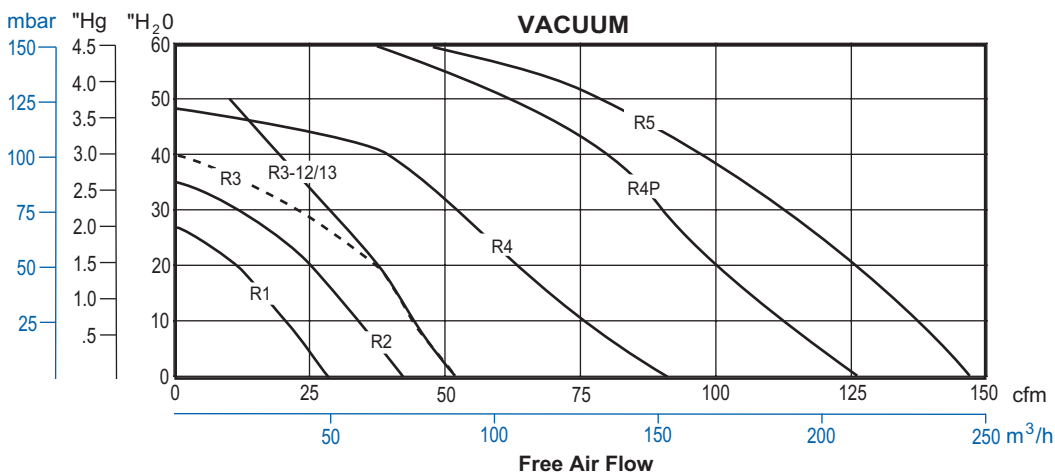
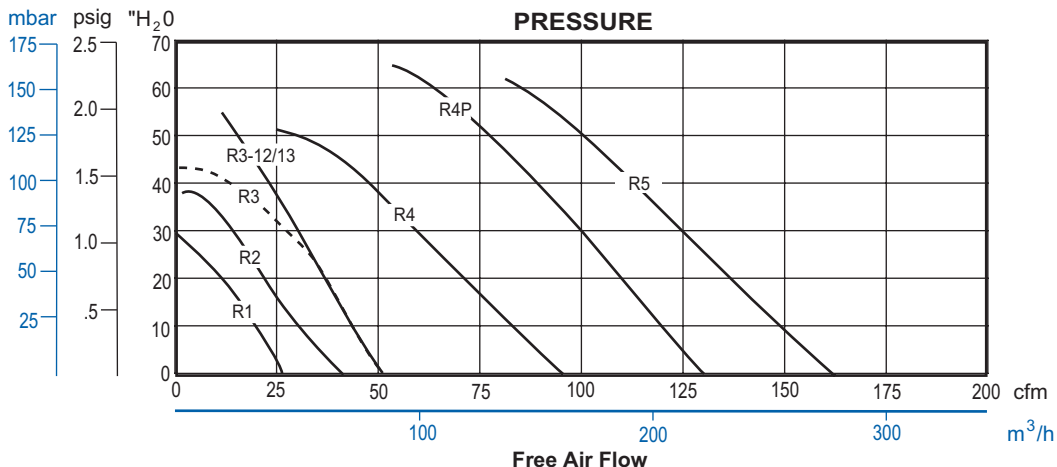

Gast advertises blower performance in Free Air Flow, or air subjected to only atmospheric pressure. (See above curves)

Some blower manufacturers advertise vacuum performance in CFM Inlet Air - measurement of the suction of air at a specific temperature at the inlet port and a specific discharge pressure at the exhaust port, which can be perceived as enhanced performance over Free Air Flow rated blowers. Therefore, we are also providing the following vacuum performance for Gast blowers in CFM Inlet Air for comparison to other blower manufacturer's advertising.

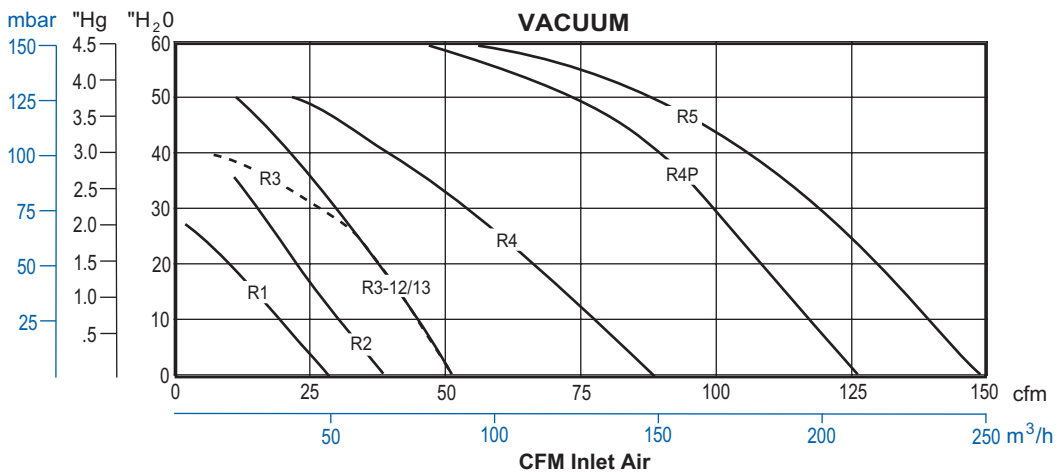

Performance Curves - Mid Range for Pressure/Vacuum

Motor mounted series R6, R6P, R6PP, R7, R7P, R9, R9P

Performance at 60 Hz

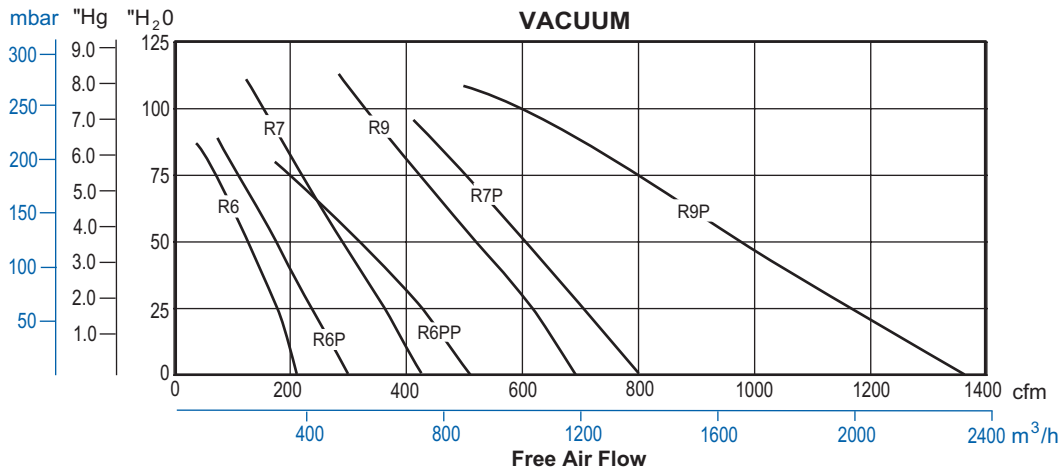
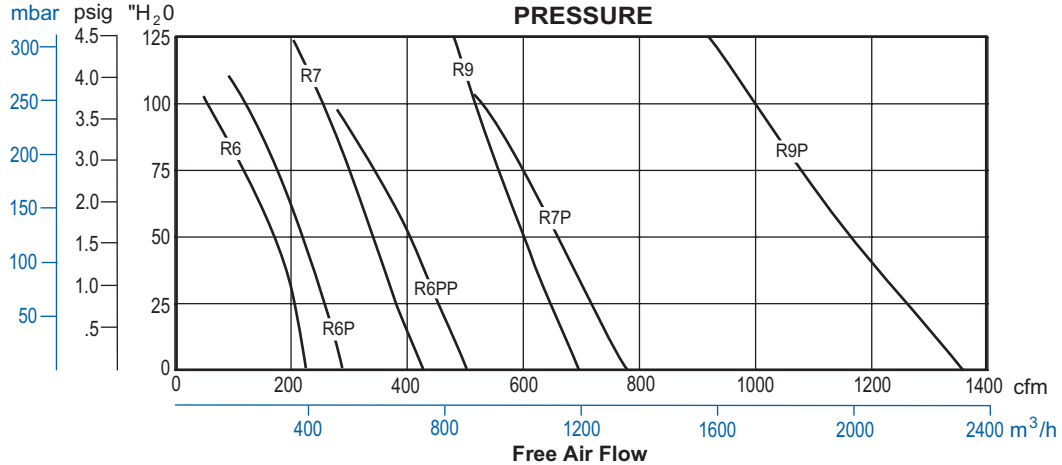

Gast advertises blower performance in Free Air Flow, or air subjected to only atmospheric pressure. (See above curves)
 Some blower manufacturers advertise vacuum performance in CFM Inlet Air - measurement of the suction of air at a specific temperature at the inlet port and a specific discharge pressure at the exhaust port, which can be perceived as enhanced performance over Free Air Flow rated blowers. Therefore, we are also providing the following vacuum performance for Gast blowers in CFM Inlet Air for comparison to other blower manufacturer's advertising.

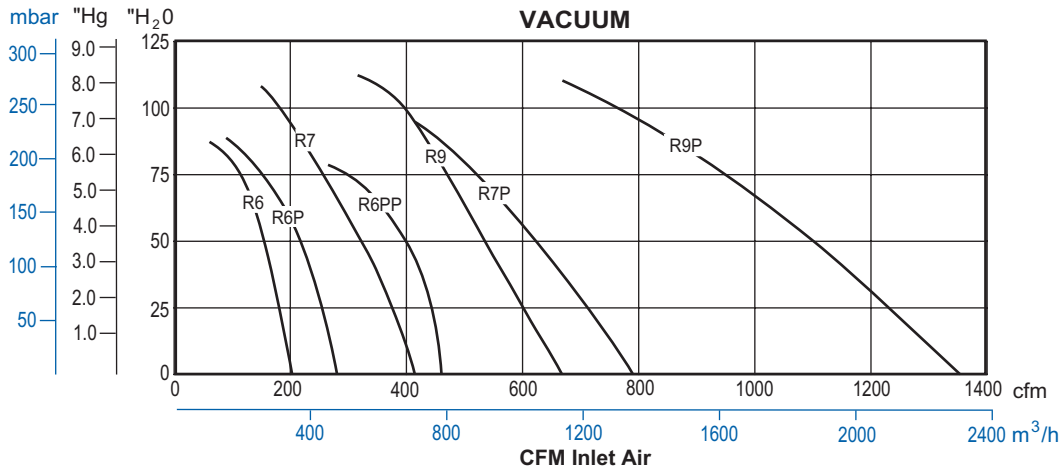



Performance Curves - High Range for Pressure/Vacuum

Motor mounted series R4H, R4H-1, R6PS, R7S, R9S

Performance at 60 Hz

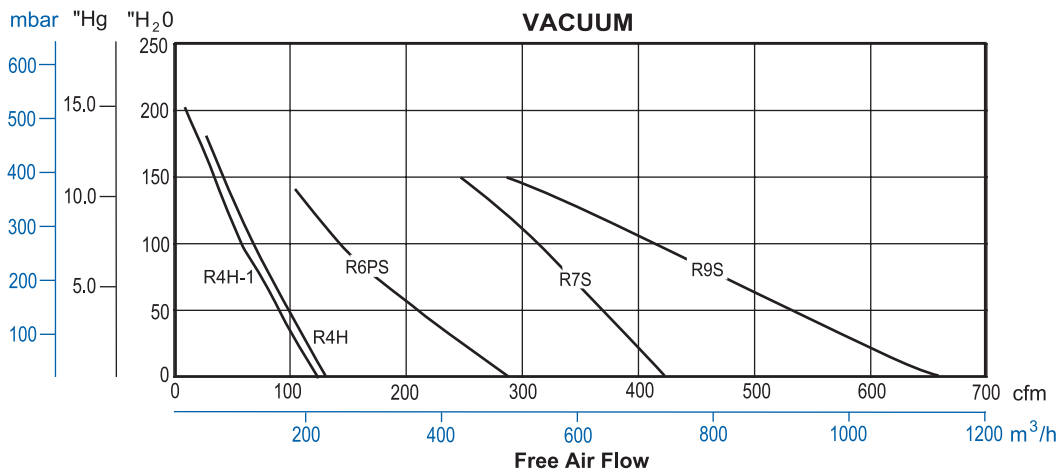
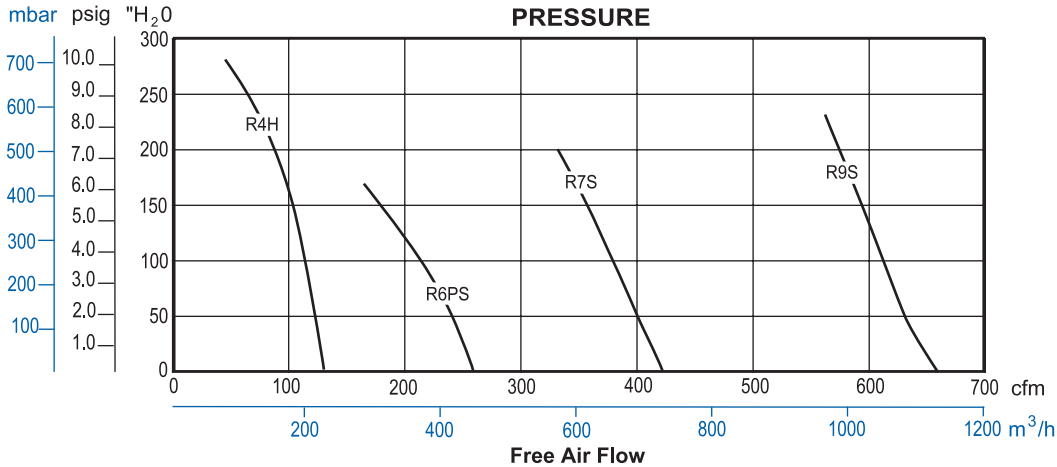

Gast advertises blower performance in Free Air Flow, or air subjected to only atmospheric pressure. (See above curves)

Some blower manufacturers advertise vacuum performance in CFM Inlet Air - measurement of the suction of air at a specific temperature at the inlet port and a specific discharge pressure at the exhaust port, which can be perceived as enhanced performance over Free Air Flow rated blowers. Therefore, we are also providing the following vacuum performance for Gast blowers in CFM Inlet Air for comparison to other blower manufacturer's advertising.

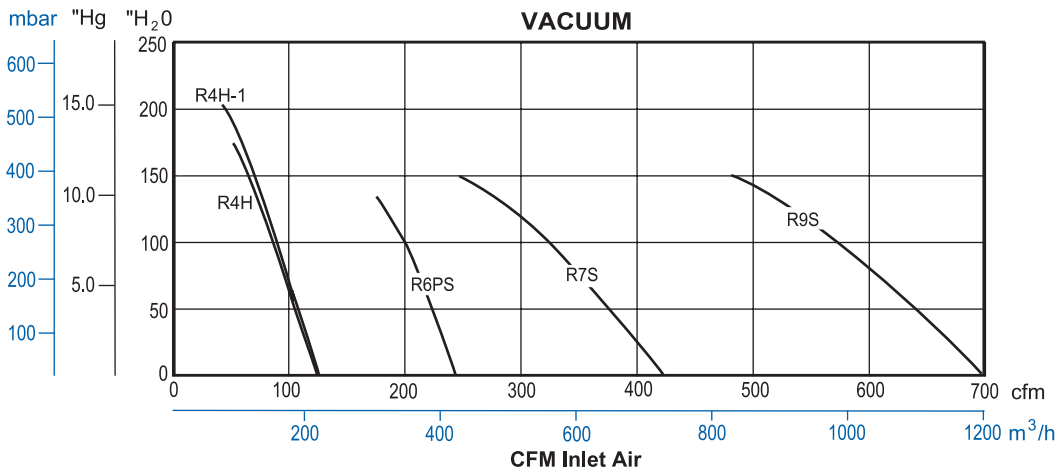

Envelope Dimensions

Model #	Net Wt. (lbs)	A Length (inches)	B Width (inches)	C Height (inches)	Inlet/Outlet Connections
R1102	16	8.86	7.80	8.51	1"
R1102C	16	8.86	7.80	8.51	1"
R1102K	16	9.21	7.80	8.51	1"
R2103	21	9.90	8.93	9.29	1"
R2105	23	10.57	8.93	9.29	1"
R2303A	23	9.90	8.93	9.29	1"
R2305B	23	10.85	8.93	9.29	1"
R3105-1	29	10.94	9.72	10.15	1 1/4"
R3105-12	29	10.94	9.72	10.15	1 1/4"
R3305A-1	29	10.94	9.72	10.15	1 1/4"
R3305A-13	29	10.94	9.72	10.15	1 1/4"
R4110-2	41	12.82	11.25	11.80	1 1/2"
R4310A-2	41	12.82	11.25	11.80	1 1/2"
R4310B-1	41	12.82	11.25	11.80	1 1/2"
R4P115	61	15.46	13.26	13.61	1 1/2"
R4P315A	43	11.38	13.26	13.61	1 1/2"
R5125-2	76	16.14	13.56	13.80	1 1/2"
R5325A-2	65	15.23	13.56	13.80	1 1/2"
R5325B-1	65	14.73	13.56	13.80	1 1/2"
R6125-2	87	16.45	15.17	15.38	2"
R6325A-2	76	15.53	15.17	15.38	2"
R6135J-10	112	15.86	15.17	15.38	2"
R6335A-2	82	16.59	15.17	15.38	2"
R6335B	82	16.00	15.17	15.38	2"
R6150J-2	125	17.46	15.17	15.38	2"
R6350A-2	112	17.35	15.17	15.38	2"
R6350B-2	112	17.35	15.17	15.38	2"
R6P335A	150	16.69	16.75	18.15	2"
R6P350A	176	17.75	16.75	18.15	2"
R6P350B	176	17.75	16.75	18.15	2"
R6P355A	215	19.92	16.75	18.15	2"
R6PP3110M	309	23.19	16.75*	18.21	2" / 3"
R7100A-3	293	22.58	18.00	20.03	2 1/2"
R7100B-1	290	21.58	18.00	20.03	2 1/2"
R7P3180M	438	28.47	18.00*	20.12	2 1/2" / 4"
R93150A	452	26.13	20.63	22.63	3"
R9P3300M	622	32.78	20.63*	22.54	3" / 5"
HIGH PRESSURE MODELS					
R4H3060A	200	21.47	16.90	18.82	2"
R4H3060A-1	200	21.47	16.90	18.82	2"
R6PS3110M	309	23.19	16.75	18.21	2"
R7S3180M	431	28.47	18.00	20.12	2 1/2"
R9S3300M	606	32.78	20.63*	22.54	3"
EXPLOSION PROOF MOTOR MODELS					
R3105N-50	52	12.3	12.75	10.15	1 1/4"
R4110N-50	60	15.34	12.34	11.80	1 1/2"
R4310P-50	58	14.09	12.34	11.80	1 1/2"
R4P115N-50	79	17.41	13.75	13.61	1 1/2"
R5125Q-50	77	17.59	13.72	13.80	1 1/2"
R5325R-50	75	16.75	13.56	13.80	1 1/2"
R6130Q-50	129	18.97	15.17	15.34	2"
R6340R-50	112	18.82	15.17	15.34	2"
R6P155Q-50	243	22.81	16.75	18.14	2"
R6P355R-50					
R7100R-50	297	22.77	18.00	20.03	2 1/2"
SEPARATE DRIVE MODELS					
SDR4	27	12.44	11.25	11.80	1 1/2"
SDR5	37	14.22	13.56	13.78	1 1/2"
SDR6	70	15.89	15.17	15.34	2"

BASIC STYLE

R1, R2, R3, R4, R4H, R4P, R5, R6, R6P, R7, R9

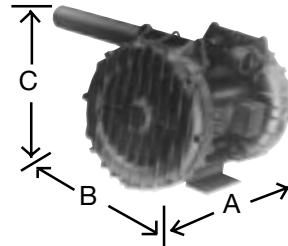
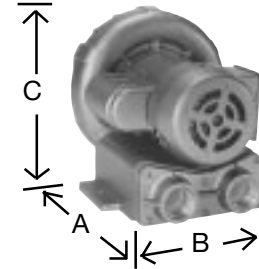

STAGED

R6PS, R7S, R9S

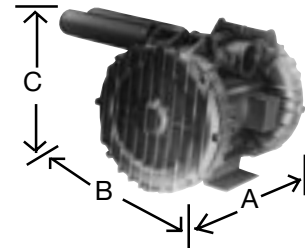

PARALLEL

R6PP, R7P, R9P

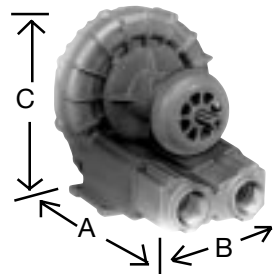

SEPARATE DRIVE

SDR4, SDR5, SDR6,

EXPLOSION PROOF MOTOR MODELS

R3, R4, R4P, R5, R6, R6P, R7

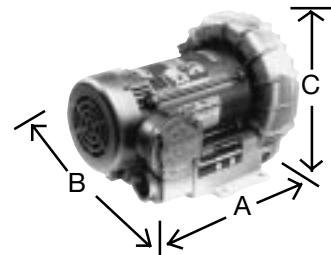

*Less muffler(s)



Imagine what you can do with air, then call Gast.

We offer cost-effective solutions to blower applications for both OEMs and end-users. Gast's Regenerative Blower line of products are designed and built to meet the changing needs of industry and are ideally suited for a number of blower applications. These are examples of many applications where Gast's Regenerative Blowers are widely used.

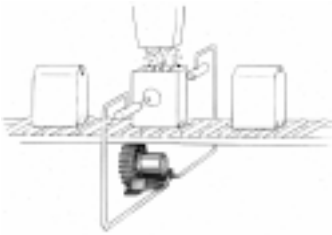

Bag Packaging Equipment

Vacuum is often used to open, hold and close bags in filling machines.

Vacuum Conveying

Plastic pellets, grain, powder and other bulk dry materials can be transported from one container to another easily using vacuum. They are pulled into a transport tube and delivered to a separator before being deposited in the final storage container.

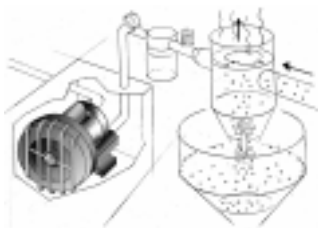

Paper Stack Air Table

The stacks of paper in all graphic arts applications are extremely heavy. To make matters more difficult, the combination of high speed presses and the various types of paper make it necessary to handle these stacks frequently. To make the job easier, these stacks are floated on an air table so they can be manipulated with very little effort.

POND AERATION

Pond aeration is done for two basic reasons. One is aquaculture, where large numbers of fish are "farmed" in a single pond. The second is ecological. As a pond or lake ages, it can lose its oxygen supply and may die. When air is introduced into a pond or lake, oxygen becomes plentiful again and life in and around the water can flourish.



PRESSURE APPLICATIONS

AGRICULTURAL EQUIPMENT

AQUACULTURE / POND AERATION
FISH HATCHERY EQUIPMENT

TRANSPORTATION EQUIPMENT

SUSPENSION SYSTEMS, TIRE INFLATORS

MEDICAL EQUIPMENT

MEDICAL AND DENTAL STERILIZING EQUIPMENT
DENTAL HAND TOOLS, AIR MATTRESS

INDUSTRIAL TOOLS AND MACHINERY

FIBERGLASS CHOPPERS
LIQUID/HYDRAULIC PUMP DRIVES
INDUSTRIAL CLEANING EQUIPMENT
CHIP REMOVAL / PARTS BLOWOFF
ENGRAVING MACHINERY

MATERIAL HANDLING EQUIPMENT

LIFT TABLES
PNEUMATIC CONVEYING SYSTEMS AND DRIVES
AUTOMATED ASSEMBLY MACHINES / ROBOTICS

COMPUTER, BUSINESS, OFFICE MACHINES AND EQUIPMENT

ENVELOPE OPENING/INSERTING/LABELING EQUIPMENT
DOCUMENT SCANNING EQUIPMENT

GRAPHIC ARTS EQUIPMENT

FOLDERS / PRESSES / COUNTERS
PHOTO PROCESSING EQUIPMENT
CORRUGATED CUTTING/PRINTING EQUIPMENT
INK JET PRINTER / POST PRESS PRINTING EQUIPMENT
COLLATING / INSERTING EQUIPMENT
INK DRYING EQUIPMENT
AIR TABLE

SPORTS AND LEISURE EQUIPMENT

SPA AND HOT TUB AERATION, AQUARIUM AERATION
HANDICAP TUB DOOR SEALS, BOAT/POND DEICING

FOOD, DRUG AND CHEMICAL EQUIPMENT

ICE CREAM/YOGURT/FROSTING DISPENSERS
PHARMACEUTICAL MANUFACTURING EQUIPMENT
AUTOMATED FOOD PREPARATION EQUIPMENT

ELECTRONICS AND COMMUNICATIONS EQUIPMENT

CABLE PRESSURIZATION / CABLE SLICING EQUIPMENT
CIRCUIT BOARD PROCESSING EQUIPMENT

ENVIRONMENT, POLLUTION AND SAFETY EQUIPMENT

AIR/WATER PURIFIERS
GAS GENERATORS (OZONE, NITROGEN)
SEWAGE TREATMENT
SMOKE EVACUATION
PEST CONTROL EQUIPMENT
SOIL/GROUNDWATER REMEDIATION EQUIPMENT

PACKAGING EQUIPMENT

MARKING/LABELING EQUIPMENT
FILLING EQUIPMENT
FOOD PACKAGING / BAG MAKING EQUIPMENT
CAN/BOTTLE MAKING EQUIPMENT
LIQUID PACKAGING EQUIPMENT
CORRUGATED SHEET MAKING EQUIPMENT

TEXTILE INDUSTRY EQUIPMENT

SEWING MACHINE EQUIPMENT, SCRAP COLLECTION EQUIPMENT

PROCESSING EQUIPMENT

MIXING EQUIPMENT
VIBRATORS/TUMBLERS
PLATING TANK AGITATION
LAUNDRY EQUIPMENT
FORMING EQUIPMENT
PARTS WASHERS / PARTS DRYING EQUIPMENT / AIR KNIVES
PLASTIC PELLET DRYING/CONVEYING

ENERGY EQUIPMENT

OIL ATOMIZATION, INDUSTRIAL BURNERS

MINING AND CONSTRUCTION EQUIPMENT

TEXTURE SPRAYING, CONCRETE AERATION

VACUUM APPLICATIONS

AGRICULTURAL EQUIPMENT

INOCULATION EQUIPMENT

MEDICAL EQUIPMENT

DENTAL VACUUM OVENS, DENTAL ASPIRATION

INDUSTRIAL TOOLS AND MACHINERY

GAS RECLAIMING EQUIPMENT
HOUSE AIR/VACUUM
INDUSTRIAL VACUUM SYSTEMS
INDUSTRIAL CLEANING EQUIPMENT
VACUUM TABLE/HOLD DOWN
DUST COLLECTION EQUIPMENT
CHIP REMOVAL
ENGRAVING MACHINERY

MATERIAL HANDLING EQUIPMENT

VACUUM HOIST
PNEUMATIC CONVEYING SYSTEMS
PNEUMATIC TUBE SYSTEMS
AUTOMATED ASSEMBLY MACHINES

COMPUTER, BUSINESS, OFFICE MACHINES AND EQUIPMENT

ENVELOPE OPENING/INSERTING/LABELING EQUIPMENT
VACUUM FEED, DOCUMENT SCANNING EQUIPMENT

GRAPHIC ARTS EQUIPMENT

FOLDERS, PRESSES
VACUUM FRAMES
PHOTO PROCESSING EQUIPMENT
PAPER COUNTERS
CAMERA/EXPOSURE EQUIPMENT
CORRUGATED CUTTING/PRINTING EQUIPMENT
COLLATING EQUIPMENT
INSERTING EQUIPMENT
POST PRESS PRINTING EQUIPMENT

FOOD, DRUG AND CHEMICAL EQUIPMENT

PHARMACEUTICAL MANUFACTURING EQUIPMENT
AUTOMATED FOOD PREPARATION EQUIPMENT

ELECTRONICS AND COMMUNICATIONS EQUIPMENT

CIRCUIT BOARD PROCESSING EQUIPMENT
CABLE SPLICING EQUIPMENT

ENVIRONMENT, POLLUTION AND SAFETY EQUIPMENT

AIR SAMPLING/MONITORING EQUIPMENT
TOILET SYSTEMS
FUME EXTRACTION
VAPOR RECOVERY
SMOKE EVACUATION
PEST CONTROL EQUIPMENT
SOIL VAPOR EXTRACTION
WEATHER PREDICTION EQUIPMENT

PACKAGING EQUIPMENT

CASE ERECTORS/PACKERS
MARKING/LABELING EQUIPMENT
BAG MAKING EQUIPMENT
FILLING EQUIPMENT
FOOD PACKAGING EQUIPMENT
CAN/BOTTLE MAKING EQUIPMENT
LIQUID PACKAGING EQUIPMENT
CORRUGATED SHEET MAKING EQUIPMENT
PACKING FILL REMOVAL EQUIPMENT

TEXTILE INDUSTRY EQUIPMENT

SEWING MACHINE EQUIPMENT
SCRAP COLLECTION EQUIPMENT
GARMENT VACUUM TABLES
TRIM REMOVAL

PROCESSING EQUIPMENT

VIBRATORS/TUMBLERS, NON-MEDICAL LAB EQUIPMENT
FORMING EQUIPMENT, PLASTIC PELLET DRYING/CONVEYING

VACUUM HOLDING OF AUTOMATED CUTTING

Lasers, water jets and knives are all precision tools for cutting a wide variety of materials automatically. These computer driven machines use vacuum to hold materials being cut in place.

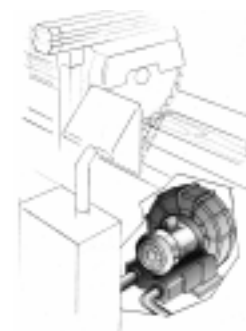
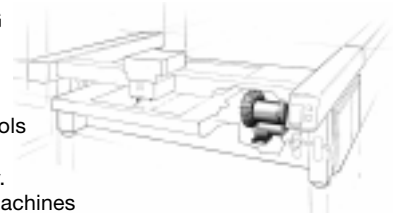

DUST AND CHIP COLLECTION

Vacuum power is used to collect dust and/or chips from saws, mills and other cutting machines.



AUTOMATED PRODUCT FEEDING

Vacuum force is used to automatically stack product as it is received or to move the product from one process to another.

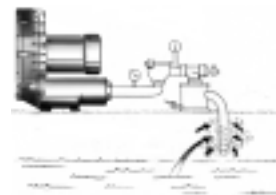

SOIL VAPOR EXTRACTION

Contaminated soil is often treated by pulling the contaminants, usually gasoline or other hydrocarbons, out of the soil with vacuum.

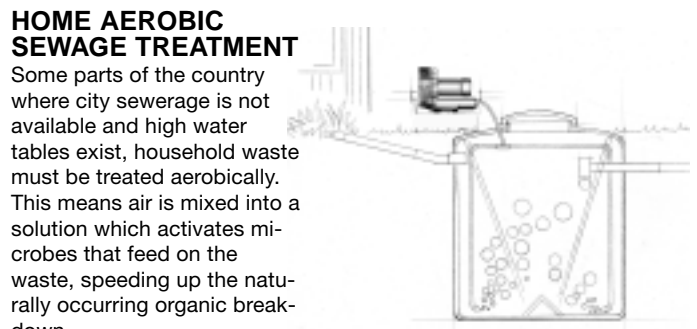

HOME AEROBIC SEWAGE TREATMENT

Some parts of the country where city sewerage is not available and high water tables exist, household waste must be treated aerobically. This means air is mixed into a solution which activates microbes that feed on the waste, speeding up the naturally occurring organic breakdown.



AC Motor



DC Motor

R1 SERIES

MODELS R1102, R1102C, R1102K

MAX. PRESSURE – 28.5”H₂O (60 Hz), 21”H₂O (50 Hz)

MAX. VACUUM – 26.5”H₂O (60 Hz), 20”H₂O (50 Hz)

MAX. AIR FLOW – 27 CFM (60 Hz), 23 CFM (50 Hz)

PRODUCT FEATURES

- Rugged construction, low maintenance
- Oilless operation
- UL and CSA approved TEFC motors with permanently sealed ball bearings
- Automatic restart thermal protection on single phase AC motors
- Estimated 3,000 hour brush life on 12 volt DC motor
- Can be operated with no air flow through unit.
- Aluminum blower housing, impeller and cover
- Can be mounted in any plane
- Inlet and outlet have internal muffling

RECOMMENDED ACCESSORIES

- Pressure gauge AJ496
- Inlet Filter AJ126B (pressure)
- Vacuum gauge AJ497
- Inline filter AJ151A (vacuum)
- Muffler AJ121B
- K899 foam replacement kit for R1102

Product Dimensions (in. mm)

MODELS R1102, R1102C, R1102K

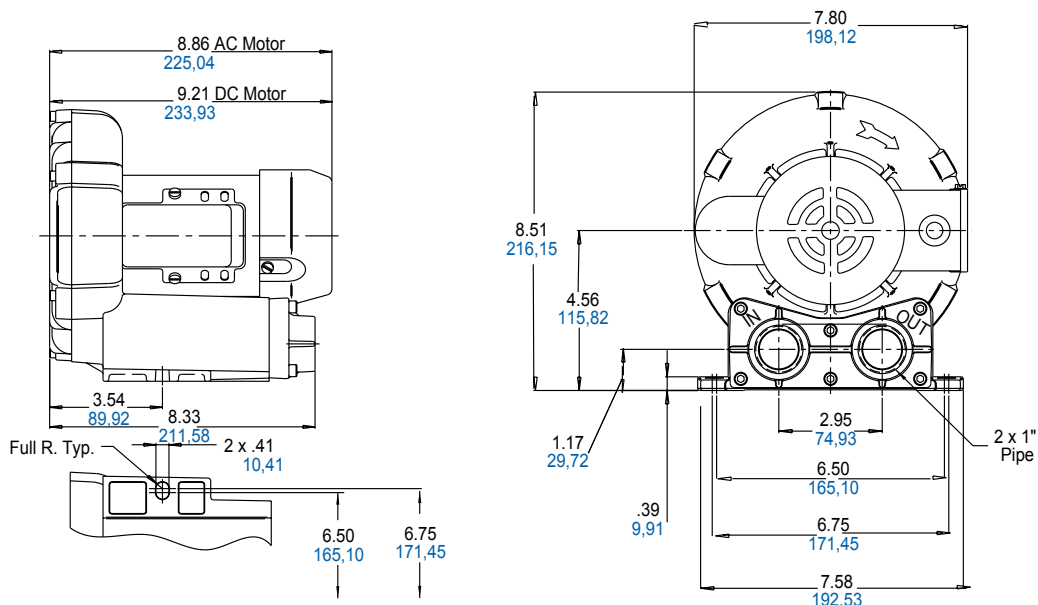

Product Specifications

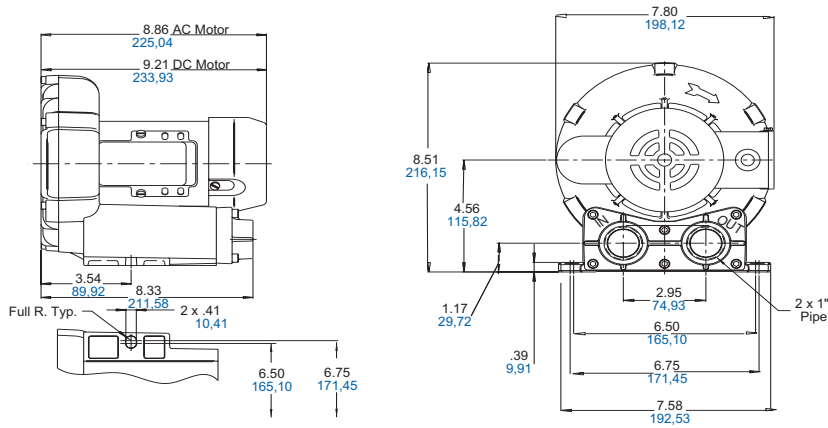

Product Performance

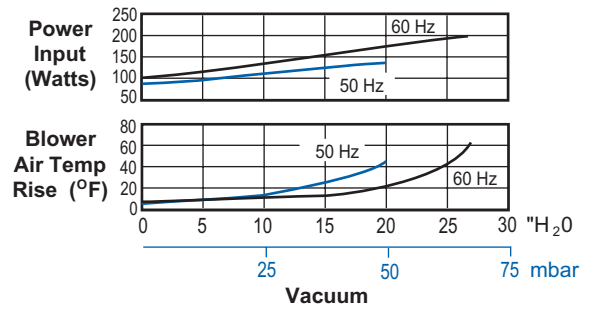
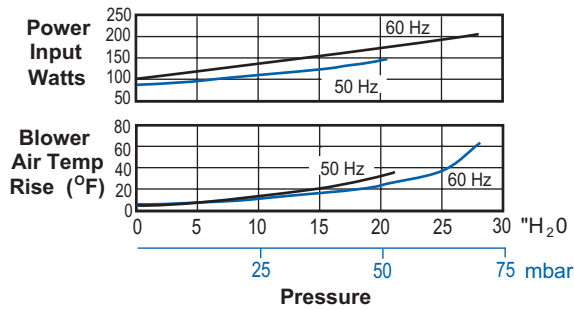
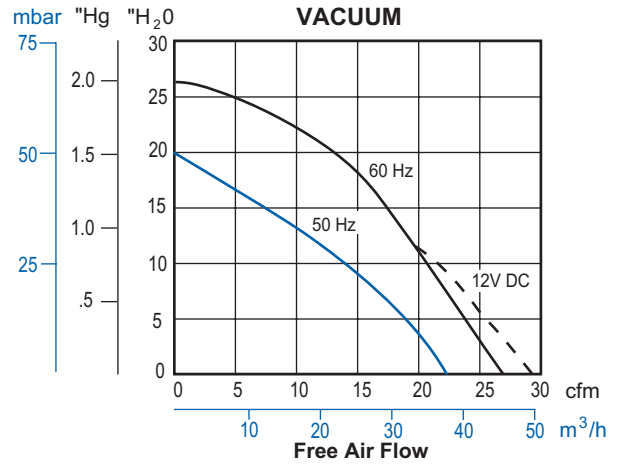
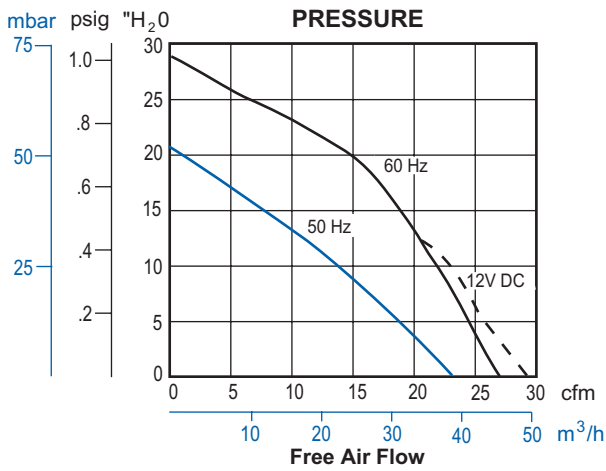



R2 SERIES

MODELS R2103, R2105, R2303A, R2305B

MAX. PRESSURE – 39"H₂O (60 Hz), 30"H₂O (50 Hz)

MAX. VACUUM – 35"H₂O (60 Hz), 25"H₂O (50 Hz)

MAX. AIR FLOW – 42 CFM (60 Hz), 33 CFM (50 Hz)



PRODUCT FEATURES

- Rugged construction, low maintenance
- Oilless operation
- UL and CSA approved TEFC motors with permanently sealed ball bearings
- Automatic restart thermal protection on single phase motors
- Aluminum blower housing, impeller and cover
- Can be operated with no air flow through unit
- Can be mounted in any plane
- Inlet and outlet have internal muffling

RECOMMENDED ACCESSORIES

- Pressure gauge AJ496
- Inlet filter AJ126B (pressure)
- Vacuum gauge AJ497
- Inline filter AJ151B (vacuum)
- Muffler AJ121B
- Foam replacement kit K900

Product Dimensions (in. mm)

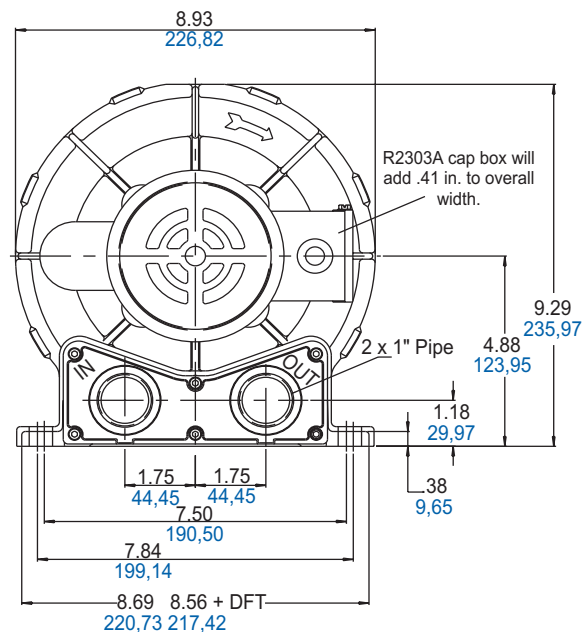
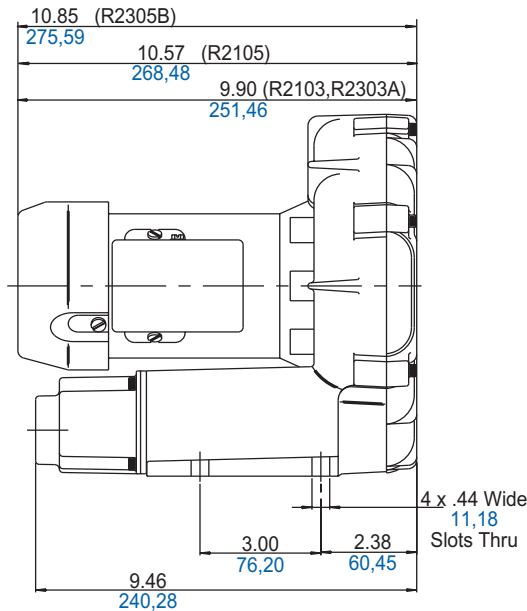

Product Specifications

MODEL NUMBER		R2103	R2105	R2303A	R2305B
Motor Enclosure		TEFC	TEFC	TEFC	TEFC
HP/kW	60 Hz	.33/0,25	.50/0,37	.33/0,25	.50/0,37
	50 Hz	.20/0,15	.33/0,25	.20/0,15	-
Voltage	60 Hz	115/208-230-1	115/208-230-1	208-230/460-3	575-3
	50 Hz	110/220-1	110/220-240-1	190-220/380-415-3	-
Amps	60 Hz	3.8/2.0-1.9	5.6/3.0-2.8	1.2-1.2/6	.7
	50 Hz	3.8/1.9	5.2/2.6-3.1	1.0-1.2/5-.53	-
Starting Amps	60 Hz	9.3 @ 230V	23.2 @ 115V	8.0 @ 230V	4.2
	50 Hz	17.6 @ 220V	23 @ 220V	8.1 @ 220V	-
Insulation Class		B	B	B	B
Recommended NEMA Starter Size		00/00	00/00	00/00	00/00
Net Weight (lbs/kg)		21/9,5	23/10,4	23/10,4	23/10,4

Product Performance

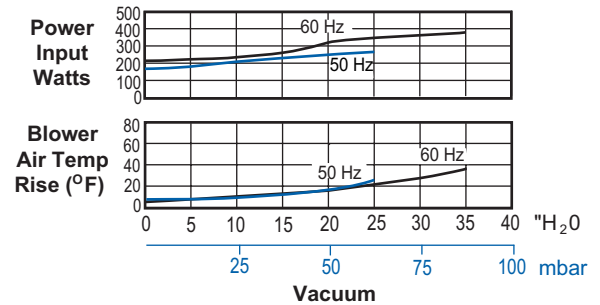
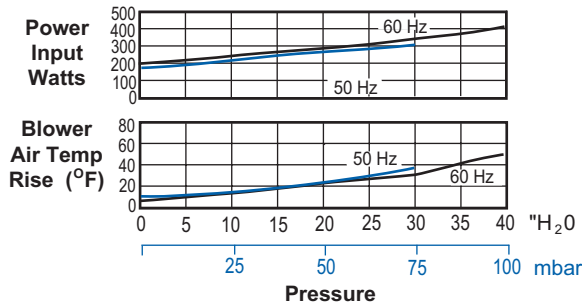
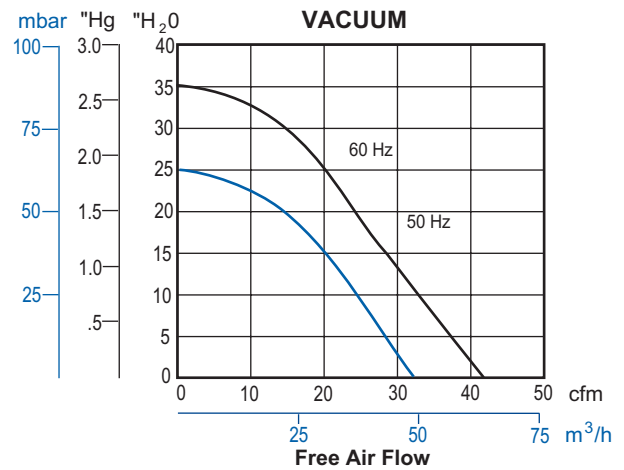
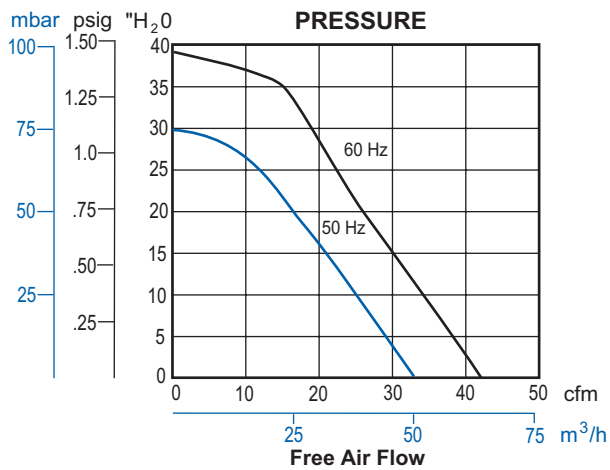



R3 SERIES

MODELS R3105-1, R3305A-1

MAX. PRESSURE – 43" H₂O (60 Hz), 31" H₂O (50 Hz)

MAX. VACUUM – 40" H₂O (60 Hz), 28" H₂O (50 Hz)

MAX. AIR FLOW – 53 CFM (60 Hz), 44 CFM (50 Hz)



PRODUCT FEATURES

- Rugged construction, low maintenance
- Oilless operation
- UL and CSA approved TEFC motors with permanently sealed ball bearings
- Automatic restart thermal protection on single phase motors
- Aluminum blower housing, impeller and cover
- Can be operated with no air flow through unit
- Can be mounted in any plane
- Inlet and outlet have internal muffling

RECOMMENDED ACCESSORIES

- Pressure gauge AJ496
- Inlet filter AJ126C (pressure)
- Vacuum gauge AJ497
- Inline filter AJ151C (vacuum)
- Muffler AJ121C
- Foam replacement kit K901

Product Dimensions (in. mm)

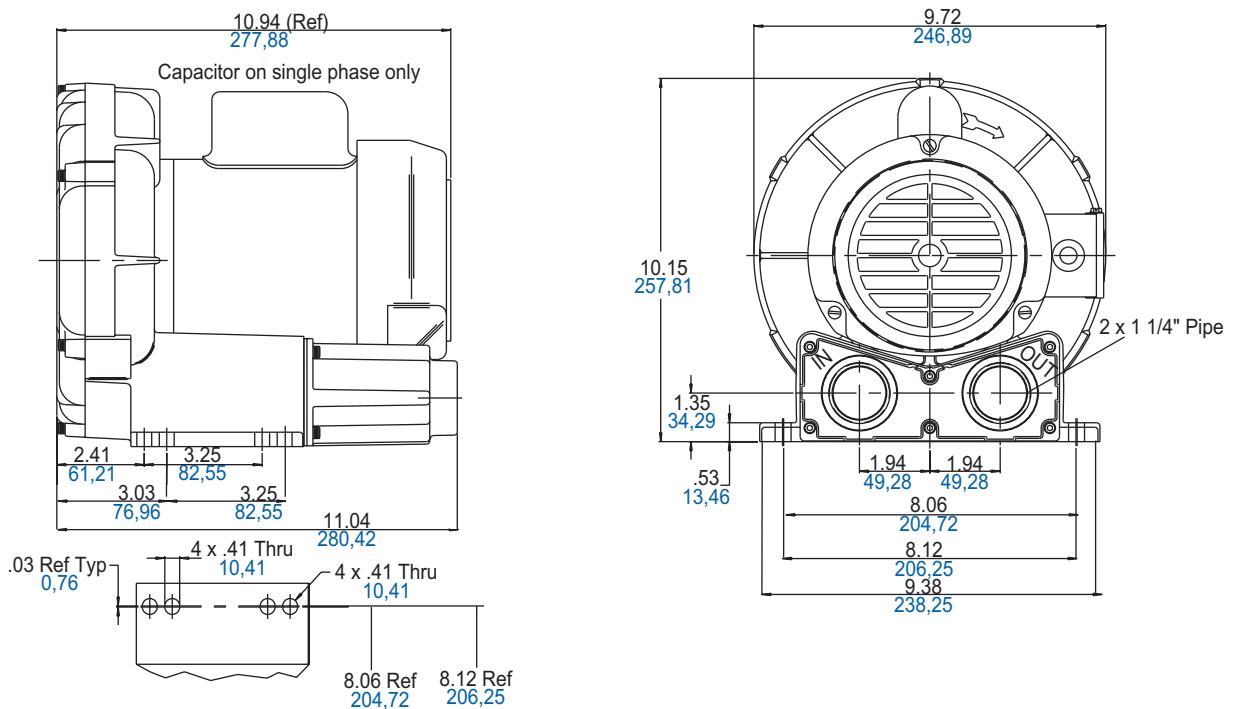

Product Specifications

MODEL NUMBER		R3105-1	R3305A-1
Motor Enclosure		TEFC	TEFC
HP/kW	60 Hz	.50/0,37	.50/0,37
	50 Hz	.33/0,25	.33/0,25
Voltage	60 Hz	115/208-230-1	208-230/460-3
	50 Hz	110/220-240-1	190-220/380-415-3
Amps	60 Hz	5.6/3.0-2.8	2.0-2.0/1.0
	50 Hz	5.2/2.6-3.1	1.6-1.8/1.8-.84
Starting Amps	60 Hz	23.2 @ 115V	10.0 @ 230V
	50 Hz	23 @ 220V	7.9 @ 220V
Insulation Class		B	B
Recommended NEMA Starter Size		00/00	00/00
Net Weight (lbs/kg)		29/13,2	29/13,2

Product Performance

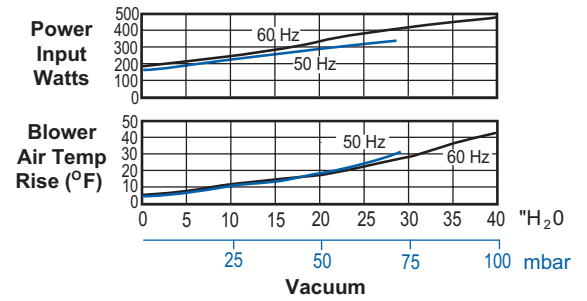
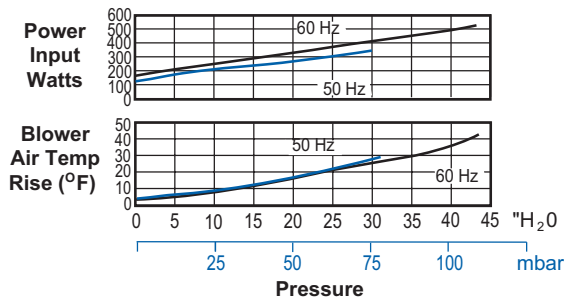
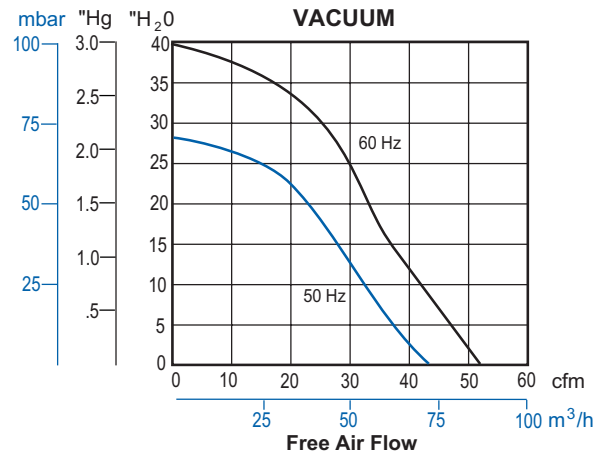
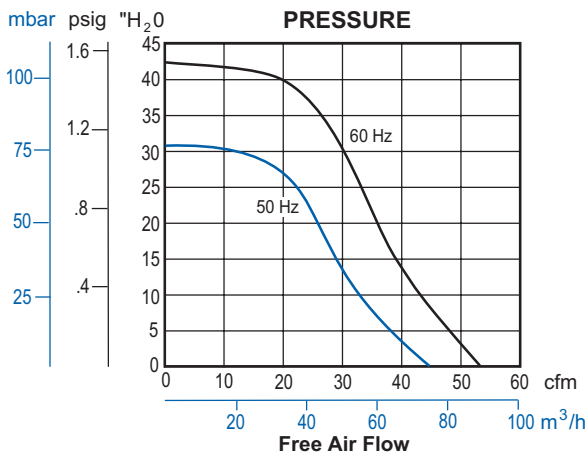



R3 SERIES HIGHER PRESSURE
MODELS R3105-12, R3305A-13

MAX. PRESSURE – 55"H₂O (60 Hz), 40"H₂O (50 Hz)

MAX. VACUUM – 50"H₂O (60 Hz), 35"H₂O (50 Hz)

MAX. AIR FLOW – 52 CFM (60 Hz), 43 CFM (50 Hz)



PRODUCT FEATURES

- Rugged construction, low maintenance
- Oilless operation
- UL and CSA approved TEFC motors with permanently sealed ball bearings
- Automatic restart thermal protection on single phase motors
- Aluminum blower housing, impeller and cover
- Can be mounted in any plane
- Inlet and outlet have internal muffling

RECOMMENDED ACCESSORIES

- Pressure gauge AJ496
- Inlet filter AJ126C (pressure)
- Vacuum gauge AJ497
- Inline filter AJ151C (vacuum)
- Muffler AJ121C

Product Dimensions (in. mm)

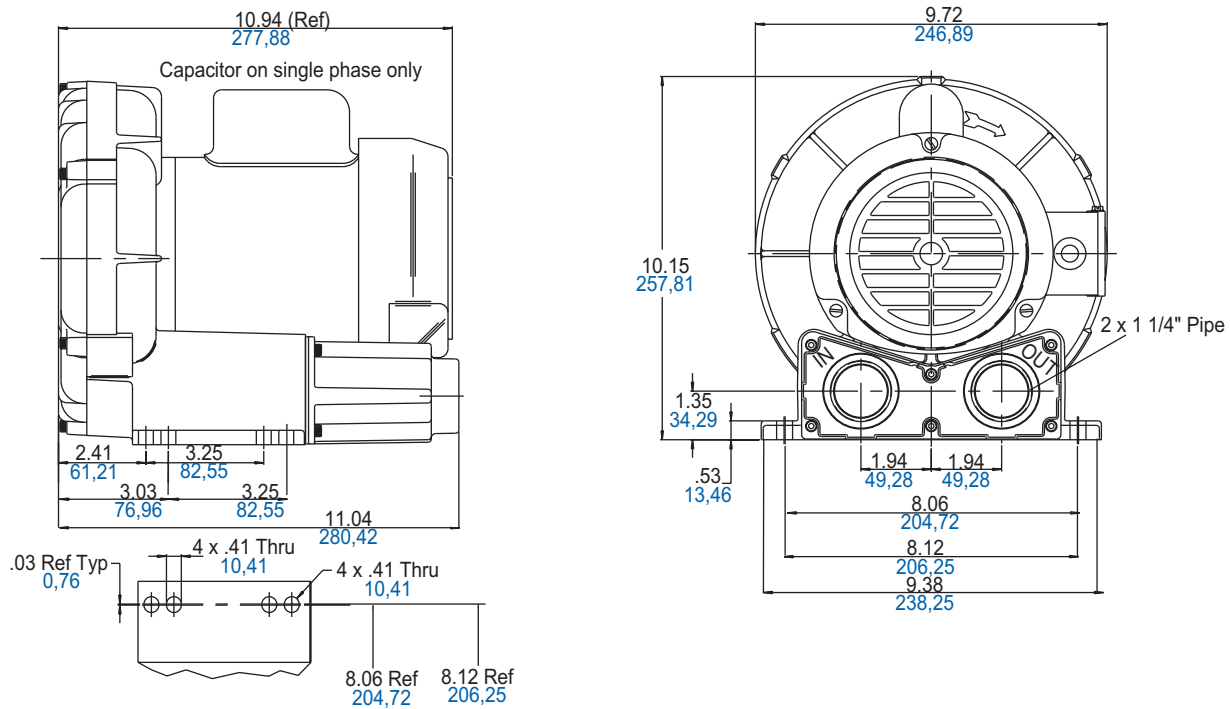

Product Specifications

MODEL NUMBER		R3105-12	R3305A-13
Motor Enclosure		TEFC	TEFC
HP/kW	60 Hz	.50/0,37	.50/0,37
	50 Hz	.33/0,25	.33/0,25
Voltage	60 Hz	115/208-230-1	208-230/460-3
	50 Hz	110/220-240-1	190-220/380-415-3
Amps	60 Hz	5.6/3.0-2.8	2.0-2.0/1.0
	50 Hz	5.2/2.6-3.1	1.6-1.8/1.8-.84
Starting Amps	60 Hz	23.2 @ 115V	10.0 @ 230V
	50 Hz	23 @ 220V	7.9 @ 220V
Insulation Class		B	B
Recommended NEMA Starter Size		00/00	00/00
Net Weight (lbs/kg)		29/13,2	29/13,2

Product Performance

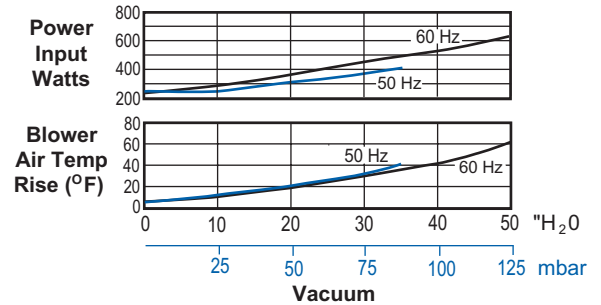
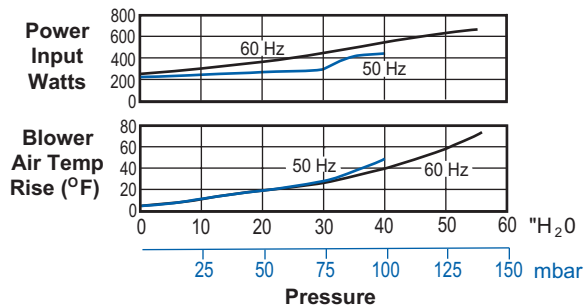
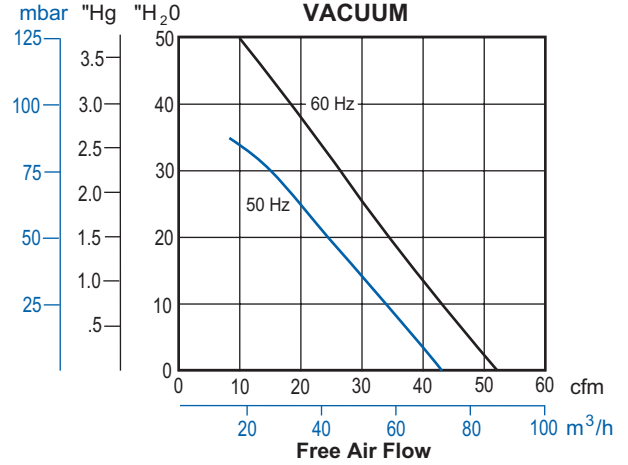
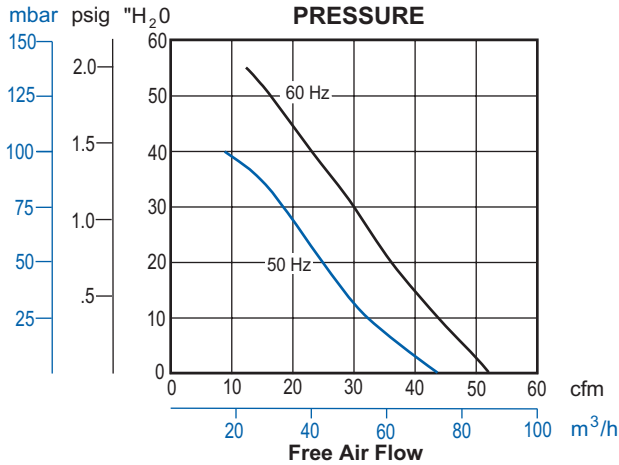



R4 SERIES

MODELS R4110-2, R4310A-2, R4310B-1

MAX. PRESSURE – 52"H₂O (60 Hz), 38"H₂O (50 Hz)

MAX. VACUUM – 48"H₂O (60 Hz), 35"H₂O (50 Hz)

MAX. AIR FLOW – 92 CFM (60 Hz), 75 CFM (50 Hz)



PRODUCT FEATURES

- Rugged construction, low maintenance
- Oilless operation
- UL and CSA approved TEFC motors with permanently sealed ball bearings
- Automatic restart thermal protection on single phase motors
- Aluminum blower housing, impeller and cover
- Can be operated with no air flow through unit
- Can be mounted in any plane
- Inlet and outlet have internal muffling

RECOMMENDED ACCESSORIES

- Pressure gauge AJ496
- Inlet filter AJ126D (pressure)
- Vacuum gauge AJ497
- Inline filter AJ151D (vacuum)
- Muffler AJ121D
- Relief valve AG258
- Liquid separator RMS160 (vacuum)
- Foam replacement kit K902

Product Dimensions (in. mm)

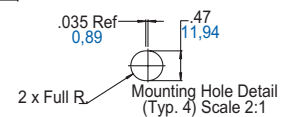
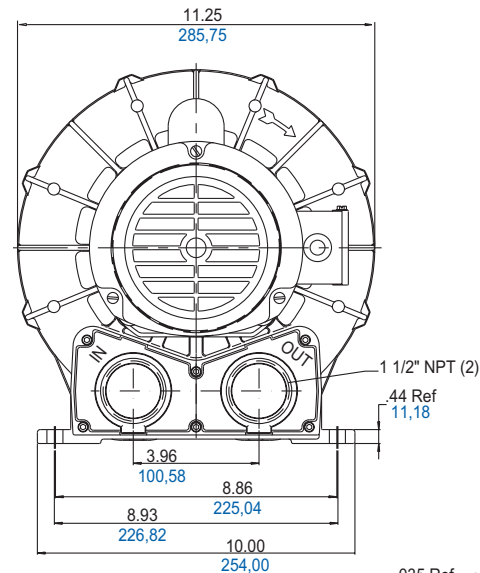
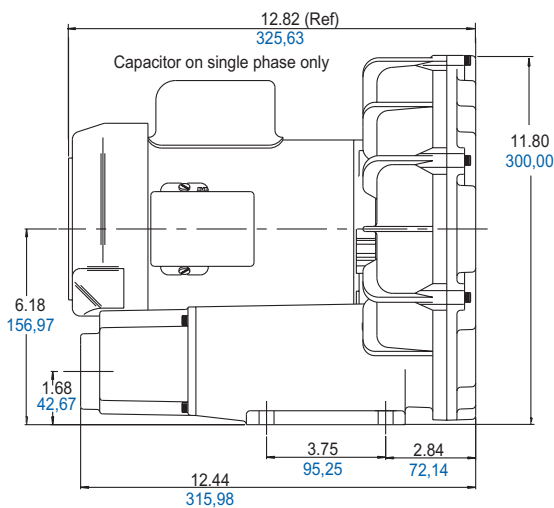

Product Specifications

MODEL NUMBER		R4110-2	R4310A-2	R4310B-1
Motor Enclosure		TEFC	TEFC	TEFC
HP/kW	60 Hz	1.0/0,75	1.0/0,75	1.0/0,75
	50 Hz	.6/0,45	.6/0,45	-
Voltage	60 Hz	115/208-230-1	208-230/460-3	575-3
	50 Hz	110/220-240-1	190-220/380-415-3	-
Amps	60 Hz	9.8/5.2-4.9	3.4-3.2/1.6	1.25
	50 Hz	9.0/4.5-5.7	2.6-3.3/1.3-1.4	-
Starting Amps	60 Hz	31.2 @ 230V	26.5 @ 230V	7.6
	50 Hz	34 @ 220V	28.4 @ 220V	-
Insulation Class		B	B	B
Recommended NEMA Starter Size		0/00	00/00	00
Net Weight (lbs/kg)		41/18,6	41/18,6	41/18,6

Product Performance

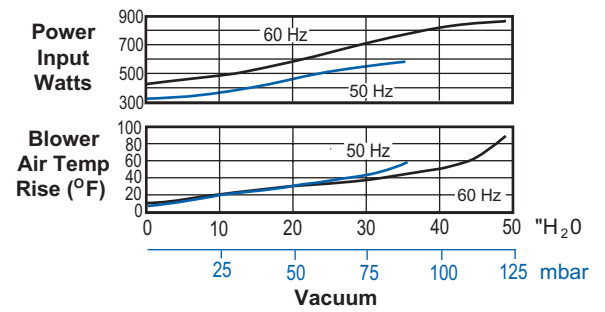
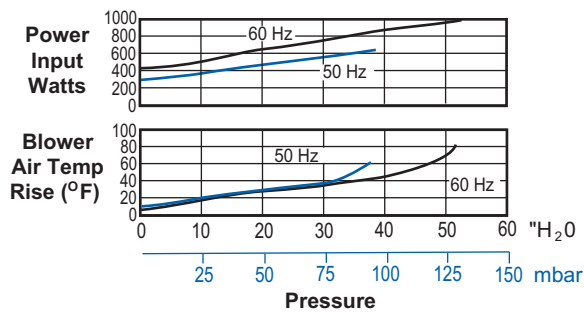
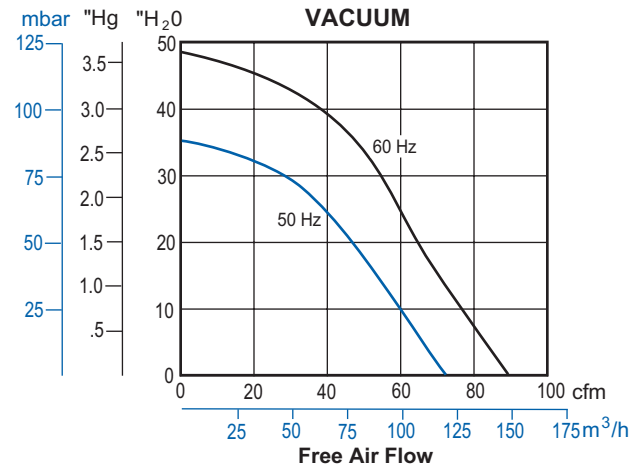
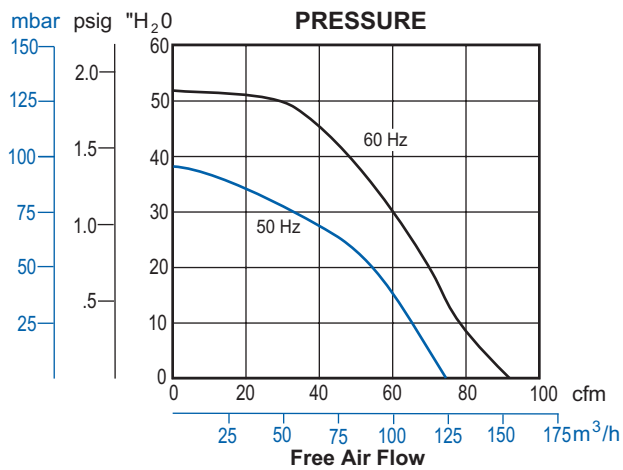



R4P SERIES

MODELS R4P115, R4P315A

MAX. PRESSURE – 65"H₂O (60 Hz), 50"H₂O (50 Hz)

MAX. VACUUM – 60"H₂O (60 Hz), 45"H₂O (50Hz)

MAX. AIR FLOW – 127 CFM (60 Hz), 110 CFM (50 Hz)



PRODUCT FEATURES

- Rugged construction, low maintenance
- Oilless operation
- UL and CSA approved TEFC motors with permanently sealed ball bearings
- Automatic restart thermal protection on single phase motors
- Aluminum blower housing, impeller and cover
- Can be mounted in any plane
- Inlet and outlet have internal muffling

RECOMMENDED ACCESSORIES

- Pressure gauge AE133
- Inlet filter AJ126D (pressure)
- Vacuum gauge AJ497
- Inline filter AJ151E (vacuum)
- Muffler AJ121D
- Relief valve AG258
- Liquid separator RMS200 (vacuum)
- Foam replacement kit K906

Product Dimensions (in. mm)

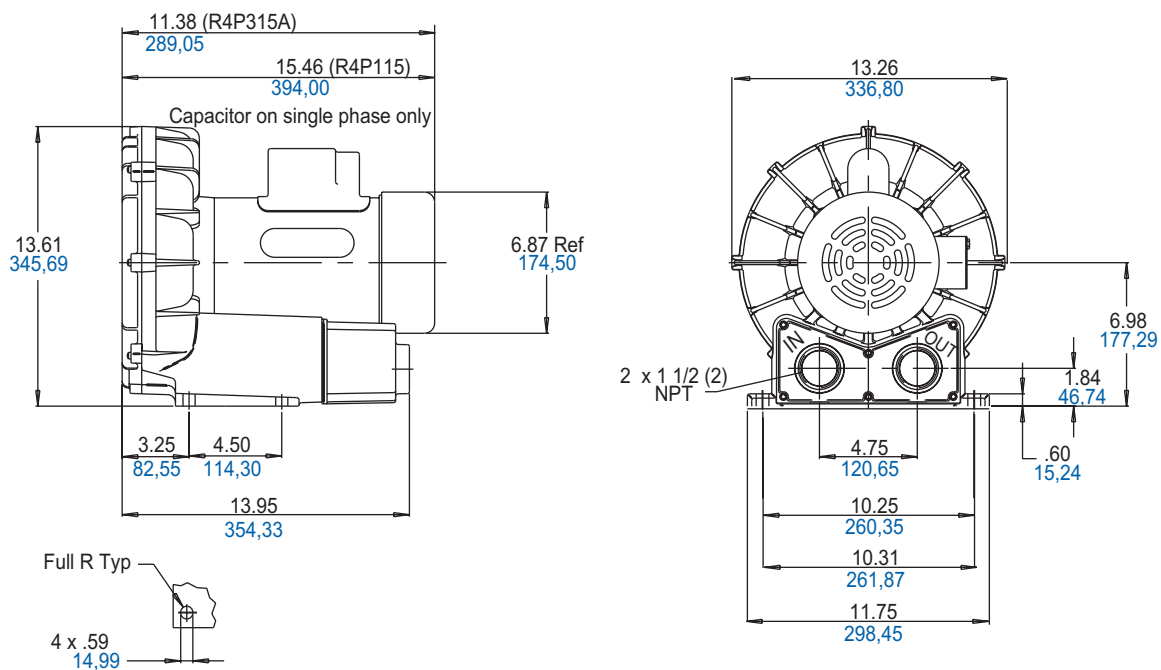

Product Specifications

MODEL NUMBER		R4P115	R4P315A
Motor Enclosure		TEFC	TEFC
HP/kW	60 Hz	1.5/1,1	1.5/1,1
	50 Hz	1.0/0,75	1.0/0,75
Voltage	60 Hz	115/208-230-1	208-230/460-3
	50 Hz	110/220-240-1	190-220/380-415-3
Amps	60 Hz	17.5/10-9	5.1-4.9/2.5
	50 Hz	14.2/8.1	3.9-4.3/1.9-2.0
Starting Amps	60 Hz	58 @ 230V	18.5 @ 460V
	50 Hz	56 @ 220V	19 @ 380V
Insulation Class		F	B
Recommended NEMA Starter Size		1/0	00/00
Net Weight (lbs/kg)		61/27,7	43/24,1

Product Performance

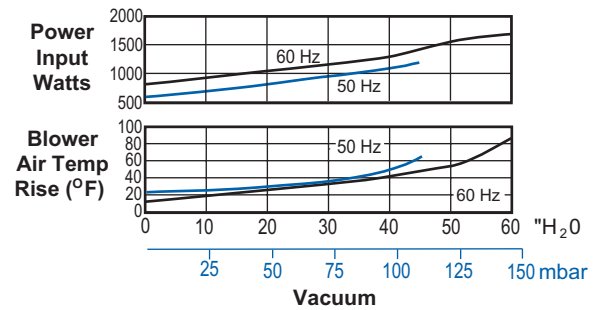
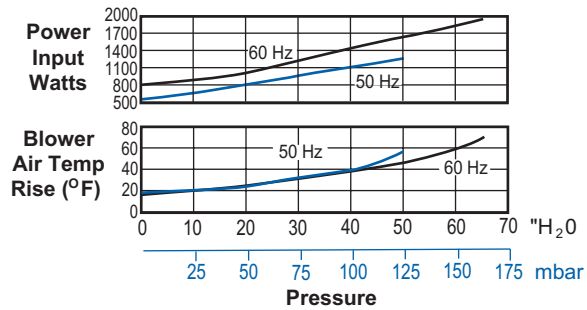
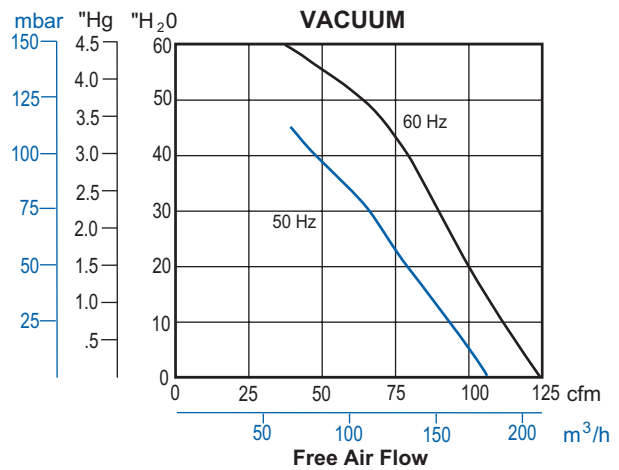
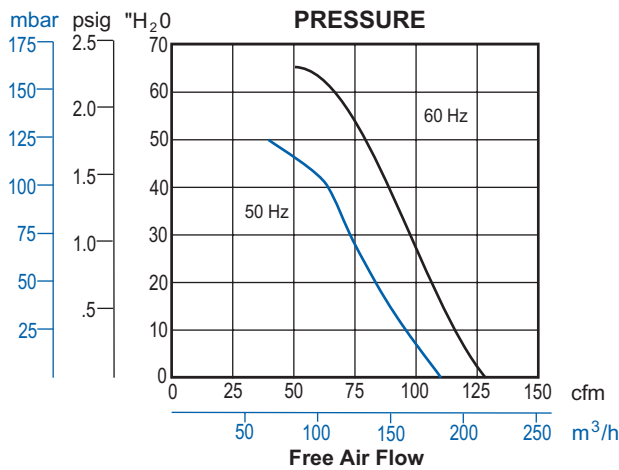



R5 SERIES

MODELS R5125-2, R5325A-2, R5325B-1

MAX. PRESSURE – 65"H₂O (60 Hz), 50"H₂O (50 Hz)

MAX. VACUUM – 60"H₂O (60 Hz), 47"H₂O (50 Hz)

MAX. AIR FLOW – 160 CFM (60 Hz), 133 CFM (50 Hz)



PRODUCT FEATURES

- Rugged construction, low maintenance
- Oilless operation
- UL and CSA approved TEFC motors with permanently sealed ball bearings
- Automatic restart thermal protection on single phase motors
- Aluminum blower housing, impeller and cover
- Can be mounted in any plane
- Inlet and outlet have internal muffling

RECOMMENDED ACCESSORIES

- Pressure gauge AE133
- Inlet Filter AJ126D (pressure)
- Vacuum gauge AJ497
- Inline filter AJ151E (vacuum)
- Muffler AJ121D
- Relief valve AG258
- Liquid separator RMS200 (vacuum)
- Foam replacement kit K903

Product Dimensions (in. mm)

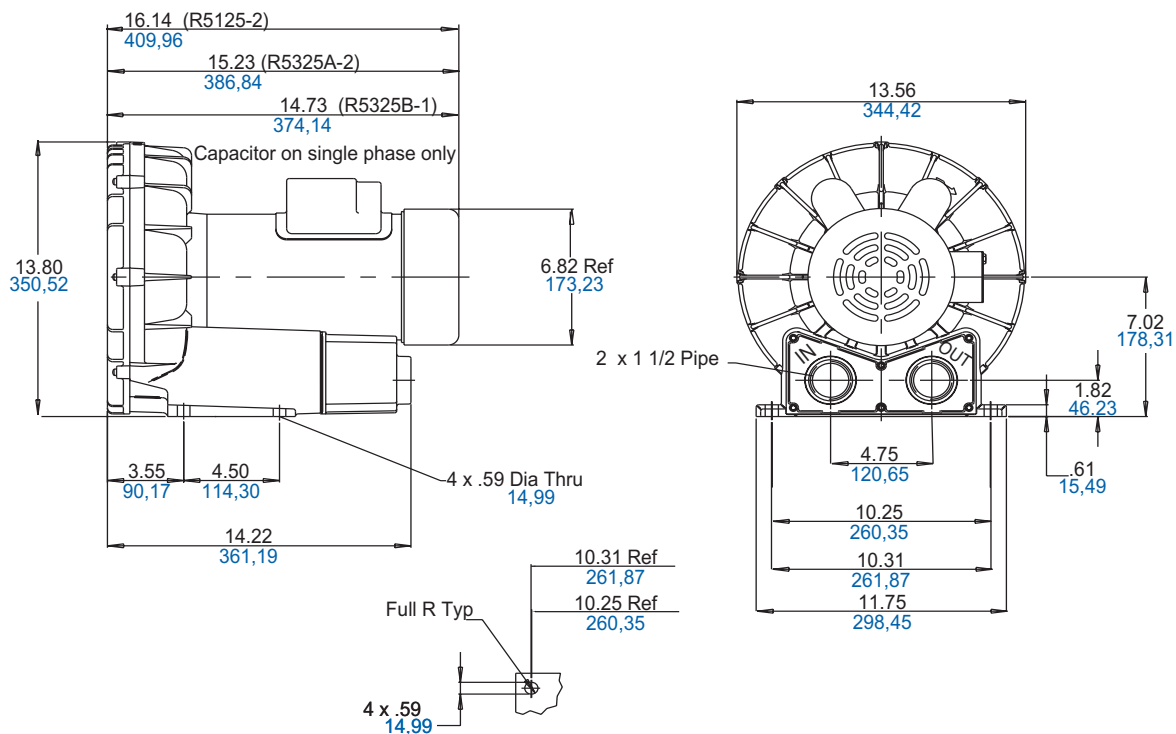

Product Specifications

MODEL NUMBER		R5125-2	R5325A-2	R5325B-1
Motor Enclosure		TEFC	TEFC	TEFC
HP/kW	60 Hz	2.5/1,9	2.5/1,9	2.5/1,9
	50 Hz	1.5/1,1	1.85/1,38	-
Voltage	60 Hz	115/208-230-1	208-230/460-3	575-3
	50 Hz	110/220-240-1	190-220/380-415-3	-
Amps	60 Hz	21/12-10	6.9-6.9/3.45	2.9
	50 Hz	16.5/8.6	6.6-6.7/3.3-3.5	-
Starting Amps	60 Hz	58 @ 230V	58 @ 230V	23.4
	50 Hz	42 @ 230V	23 @ 380V	-
Insulation Class		F	B	B
Recommended NEMA Starter Size		1/0	0/00	0
Net Weight (lbs/kg)		76/34,5	65/29,5	65/29,5

Product Performance

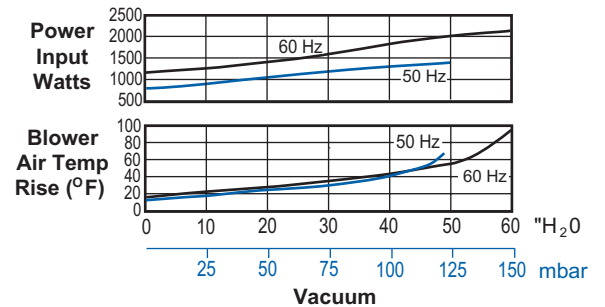
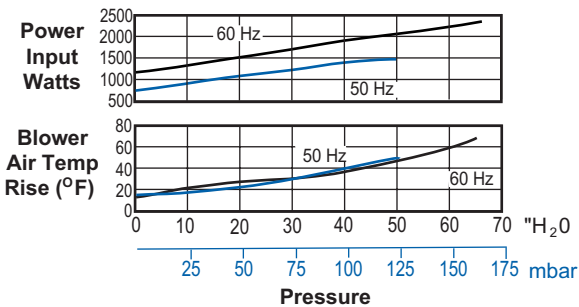
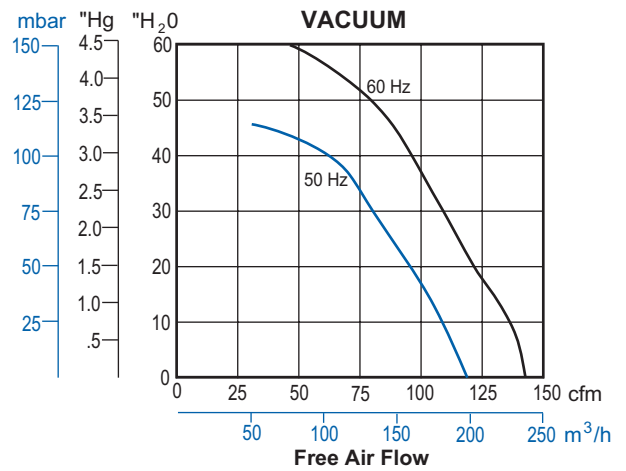
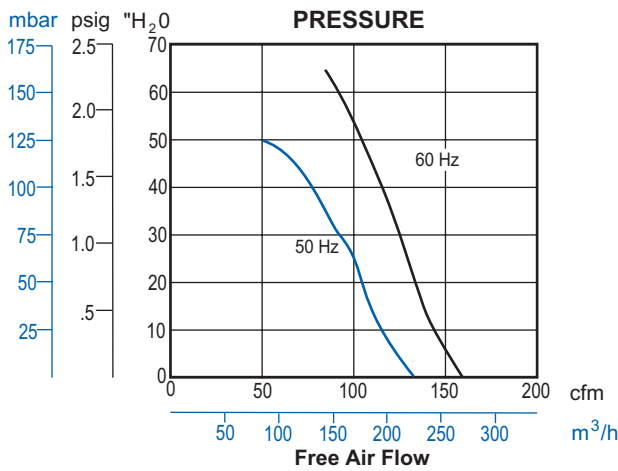



R6 SERIES

MODELS R6125-2, R6325A-2, R6135J-10, R6335A-2, R6335B, R6150J-2, R6350A-2, R6350B-2

MAXIMUM PRESSURE, VACUUM AND AIR FLOW VARIES FOR THE R6 SERIES, DEPENDING ON THE MODEL(S). REFERENCE THE CHART FOR THE SPECIFIC MODEL PERFORMANCE

PRODUCT FEATURES

- Made in the U.S.A.
- Rugged construction, low maintenance
- Oilless operation
- UL and CSA approved TEFC motors with permanently sealed ball bearings (R6150J-2 and R6135J-10 has ODP motor)
- Automatic restart thermal protection on R6150J-2, R6125-2, R6335A-2, R6325A-2
- Aluminum cover, impeller and housing
- Inlet and outlet have internal muffling

RECOMMENDED ACCESSORIES

- Pressure gauge AE133
- Inlet filter AJ126F (pressure)
- Vacuum gauge AE134
- Inline filter AJ151G (vacuum)
- Muffler AJ121F
- Relief valve AG258
- Liquid separator RMS300 (vacuum)
- Foam replacement kit K904

MODELS	Maximum Pressure ("H ₂ O)		Maximum Vacuum ("H ₂ O)		Maximum Air Flow (CFM)	
	60 Hz	50 Hz	60 Hz	50 Hz	60 Hz	50 Hz
R6125-2 R6325A-2	45	40	55	50	215	180
R6135J-10 R6335A-2 R6335B	80	75	80	65	215	180
R6150J-2 R6350A-2 R6350B-2	105	78	88	70	207	180

Product Dimensions (in. mm)

Note: Unit must be mounted horizontally, foot pad down

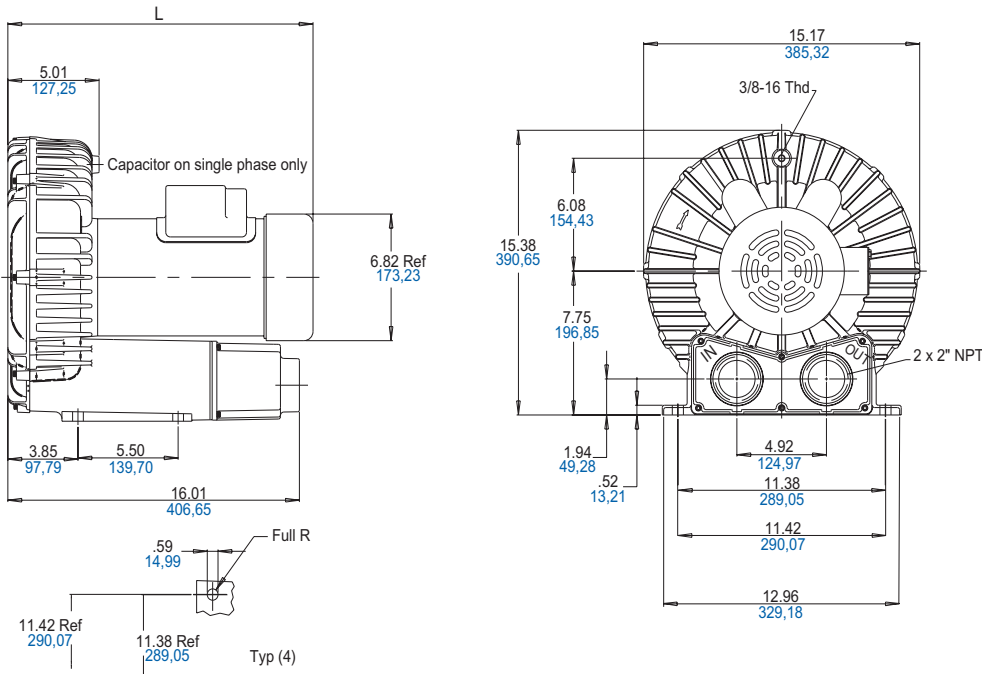

MODEL	L (in)	L (mm)
R6125-2	16.45	418
R6325A-2	15.53	394
R6135J-10	15.86	403
R6335A-2	16.59	421
R6335B	16.00	406
R6150J-2	17.46	443
R6350A-2	17.35	441
R6350B-2	17.35	441



Product Specifications

MODEL NUMBER		R6125-2	R6325A-2	R6135J-10	R6335A-2
Motor Enclosure		TEFC	TEFC	ODP	TEFC
HP/kW	60 Hz	2.5/1,9	2.5/1,9	3.5/2,6	3.5/2,6
	50 Hz	1.5/1,1	1.85/1,38	-	2.5/1,9
Voltage	60 Hz	115/208-230-1	208-230/460-3	230-1	208-230/460-3
	50 Hz	110/220-240-1	190-220/380-415-3	-	190-220/380-415-3
Amps	60 Hz	22/12.5-11	6.9-6.9/3.45	19	9.7-8.8/4.4
	50 Hz	18/9.5	6.6-6.7/3.3-3.5	-	8.8/4-3.9
Starting Amps	60 Hz	58 @ 230V	58 @ 230V	125 @ 230V	50 @ 460V
	50 Hz	42 @ 240V	23.5 @ 380V	-	40.5 @ 380V
Insulation Class		B	B	F	F
Recommended NEMA Starter Size		1/0	0/00	1P	1/0
Net Weight (lbs/kg)		87/39,5	76/34,5	112/50,8	82/37,2

MODEL NUMBER		R6335B	R6150J-2	R6350A-2	R6350B-2
Motor Enclosure		TEFC	ODP	TEFC	TEFC
HP/kW	60 Hz	3.5/2,6	5.0/3,7	5.0/3,7	5.0/3,7
	50 Hz	-	-	4.8/3,6	-
Voltage	60 Hz	575-3	230-1	208-230/460-3	575-3
	50 Hz	-	-	190-220/380-415-3	-
Amps	60 Hz	3.6	22.3	13.0-12.0/6.0	4.8
	50 Hz	-	-	14.4-13.4/7.2-6.8	-
Starting Amps	60 Hz	34.9 @ 575V	96 @ 230V	125 @ 230V	35 @ 575V
	50 Hz	-	-	57 @ 380V	-
Insulation Class		F	F	F	F
Recommended NEMA Starter Size		0	1P	1/0	0
Net Weight (lbs/kg)		82/37,2	125/56,8	112/50,8	112/50,8

Product Performance

Models R6125-2, R6325A-2

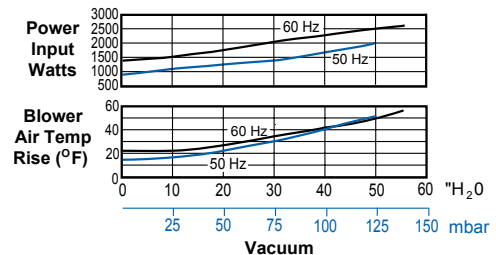
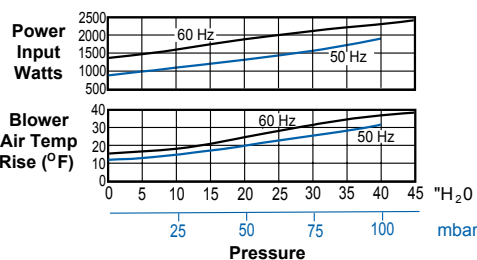
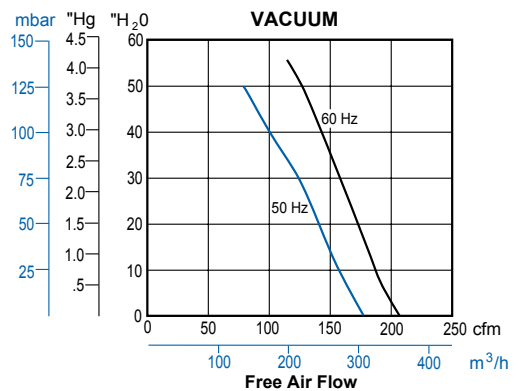
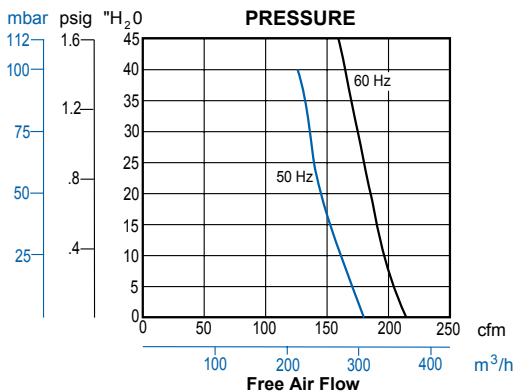

Product Performance

Models R6135J-10, R6335A-2, R6335B

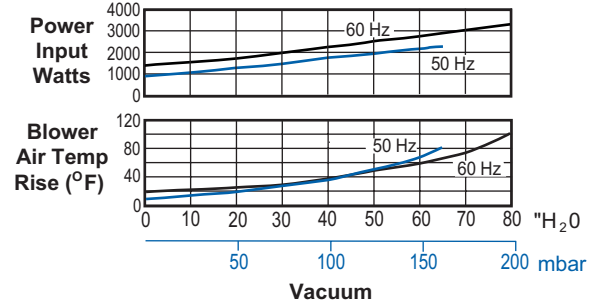
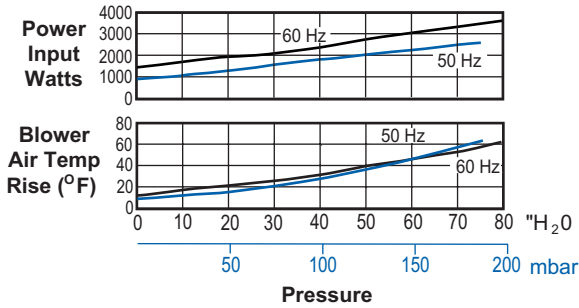
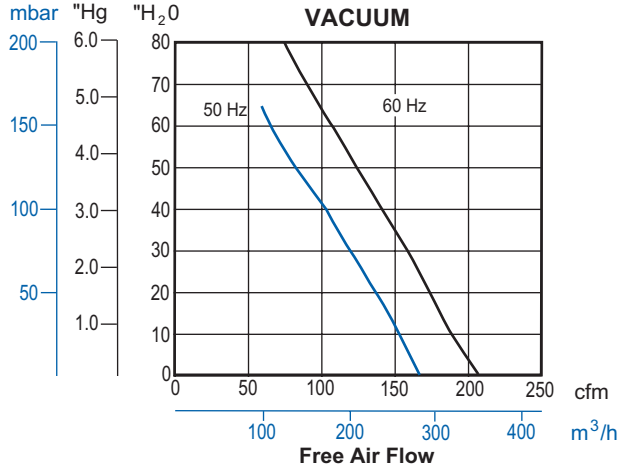
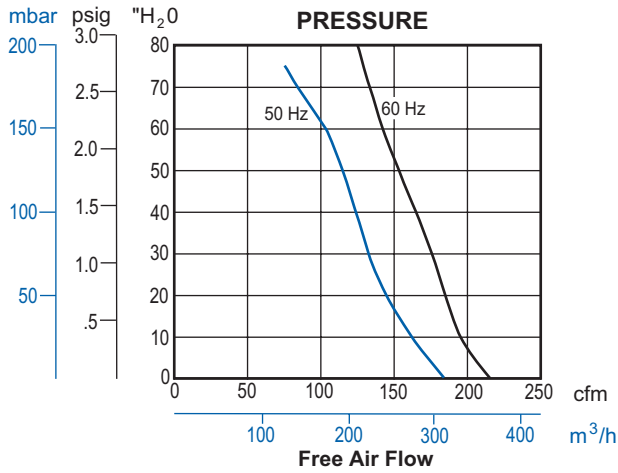

Models R6150J-2, R6350A-2, R6350B-2

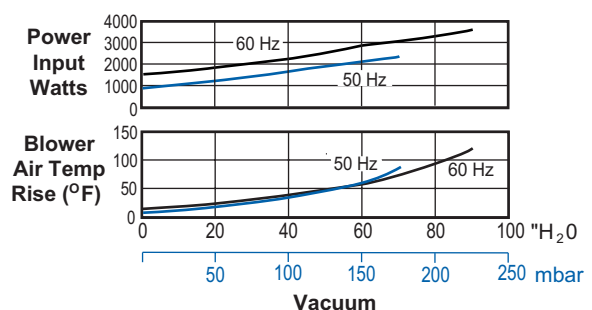
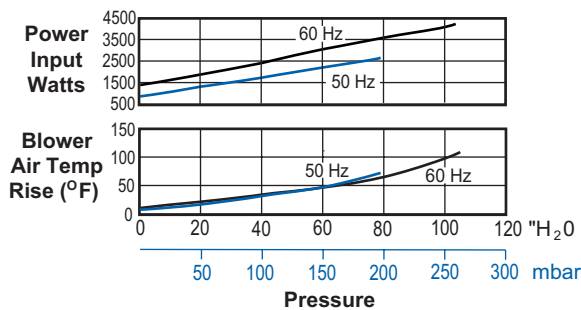
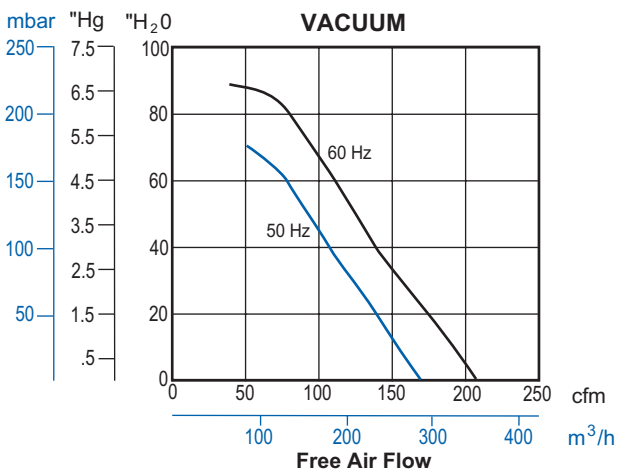
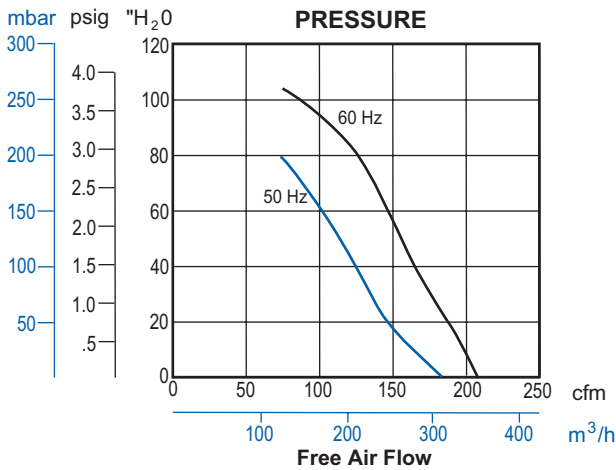



R6P SERIES

MODELS R6P335A, R6P350A, R6P350B, R6P355A

MAXIMUM PRESSURE, VACUUM AND AIR FLOW VARIES FOR THE R6P SERIES, DEPENDING ON THE MODEL(S). REFERENCE THE CHART FOR THE SPECIFIC MODEL PERFORMANCE

PRODUCT FEATURES

- Rugged construction, low maintenance
- Oilless operation
- UL and CSA approved TEFC motors with permanently sealed ball bearings
- Aluminum cover, impeller and housing
- Inlet and outlet have internal muffling

RECOMMENDED ACCESSORIES

- Pressure gauge AE133
- Inlet filter AJ126F (pressure)
- Vacuum gauge AE134
- Inline filter AJ151G (vacuum)
- Muffler AJ121F
- Relief valve AG258
- Liquid separator RMS300 (vacuum)
- Foam replacement kit K907

MODELS	Maximum Pressure ("H ₂ O)		Maximum Vacuum ("H ₂ O)		Maximum Air Flow (CFM)	
	60 Hz	50 Hz	60 Hz	50 Hz	60 Hz	50 Hz
R6P335A	30	50	35	60	265	230
R6P350A R6P350B	60	70	70	70	290	245
R6P355A	110	85	90	70	265	225

Product Dimensions (in. mm)

Note: Unit must be mounted horizontally, foot pad down

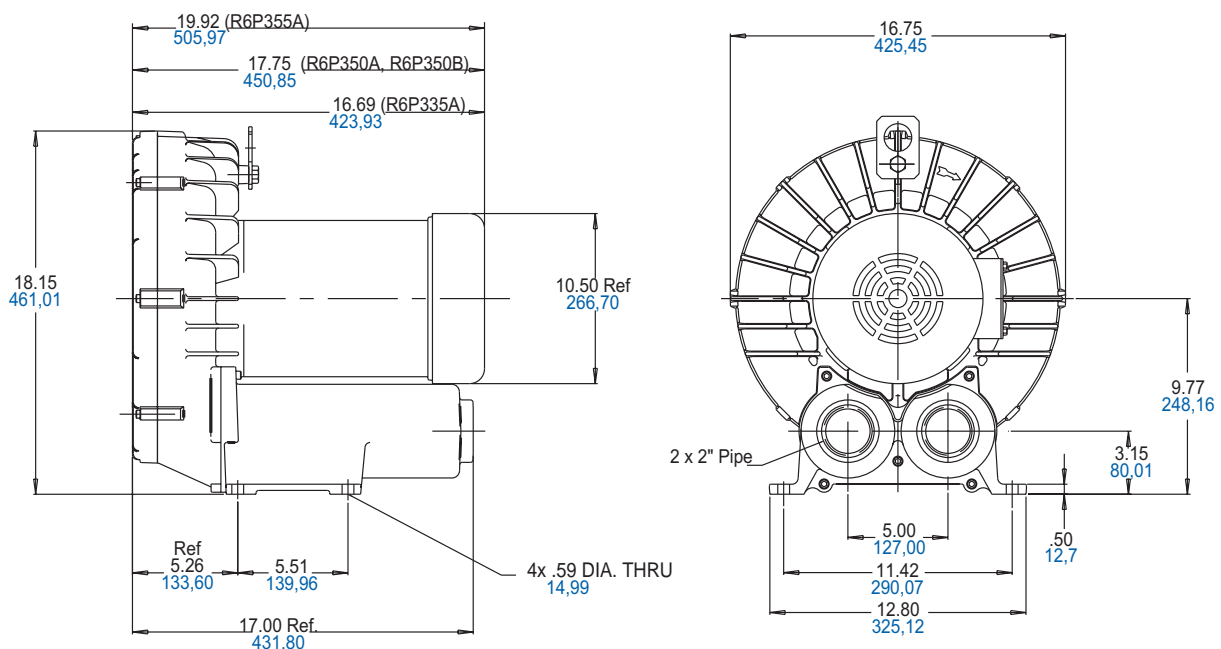

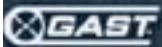

Product Specifications

MODEL NUMBER		R6P335A	R6P350A	R6P350B	R6P355A
Motor Enclosure		TEFC	TEFC	TEFC	TEFC
HP/kW	60 Hz	3.5/2,6	5.0/3,7	5.0/3,7	5.5/4,1
	50 Hz	2.5/1,9	4.8/3,6	-	5.0/3,7
Voltage	60 Hz	208-230/460-3	208-230/460-3	575-3	208-230/460-3
	50 Hz	190-220/380-415-3	190-220/380-415-3	-	190-220/380-415-3
Amps	60 Hz	9.7-8.8/4.4	13.0-12.0/6.0	4.8	19.5-18.2/9.1
	50 Hz	8-8/4-3.9	14.4-13.4/7.2-6.8	-	14.2-13.4/7.1
Starting Amps	60 Hz	50 @ 460V	125 @ 230V	35 @ 575V	83 @ 460V
	50 Hz	40.5 @ 380V	57 @ 380V	-	72 @ 380V
Insulation Class		F	F	F	F
Recommended NEMA Starter Size		1/0	1/0	0	1/0
Net Weight (lbs/kg)		150/68	176/80	176/80	215/98

Product Performance

Model R6P335A

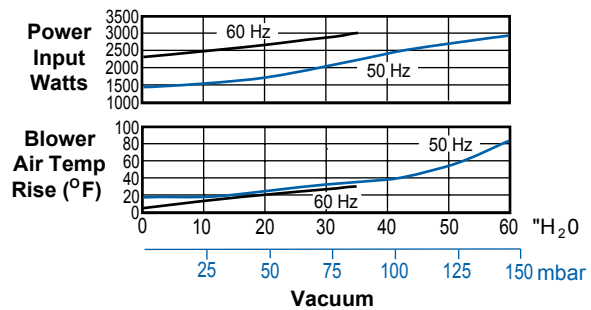
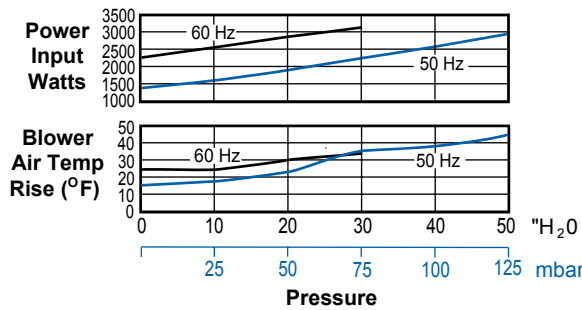
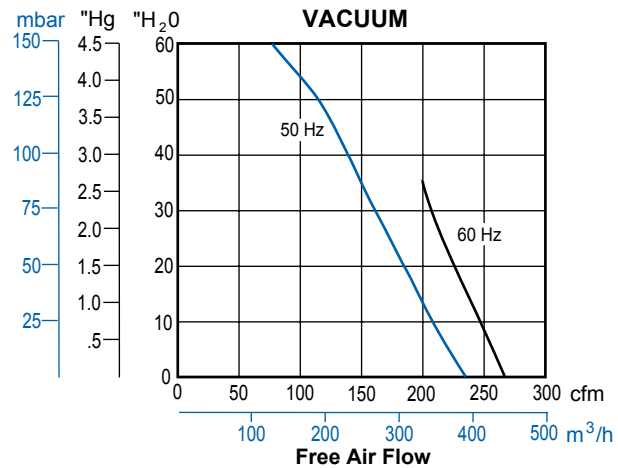
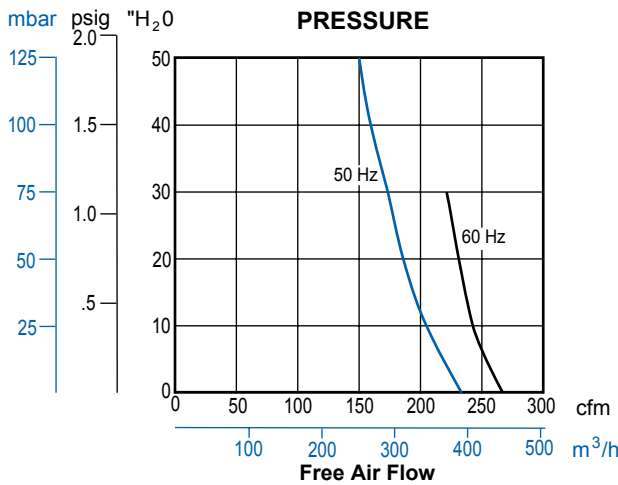



Product Performance

Models R6P350A, R6P350B

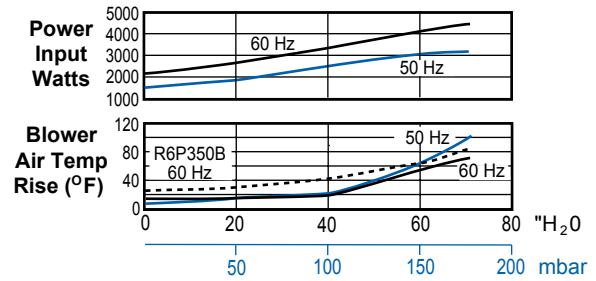
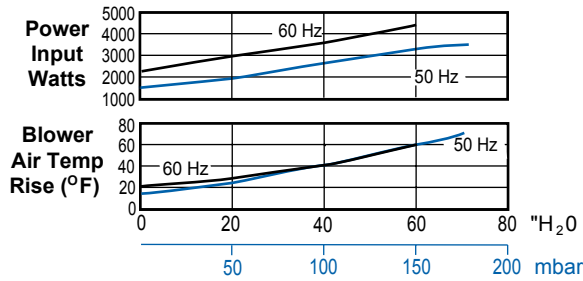
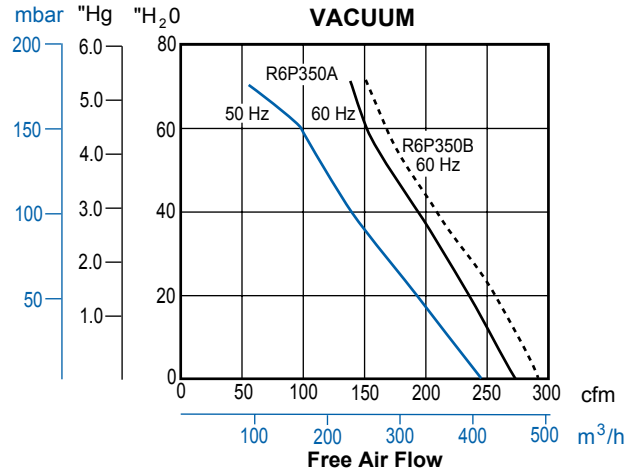
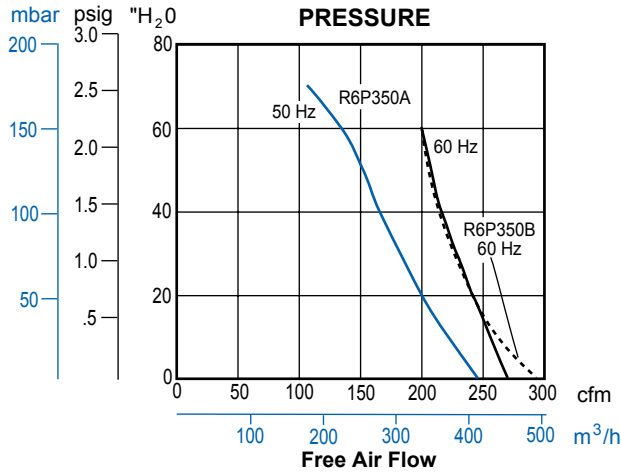

Product Performance

Model R6P355A

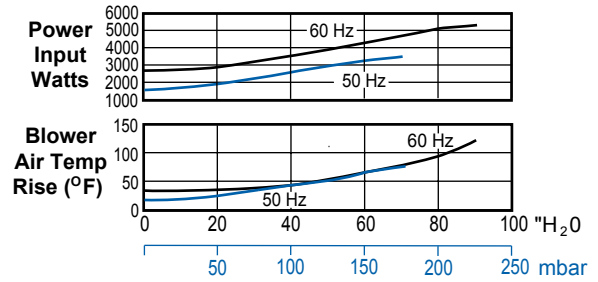
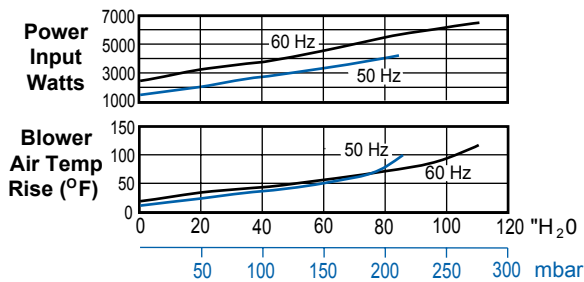
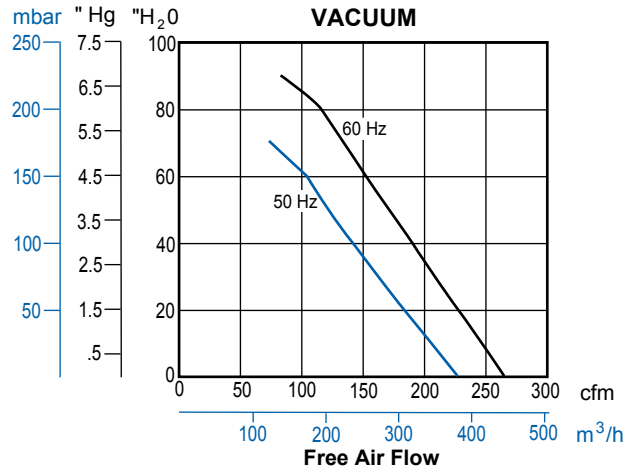
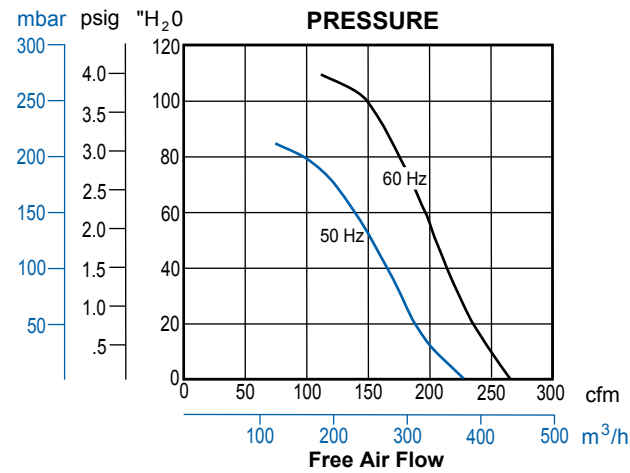



R6PP SERIES

MODELS R6PP3110M (PARALLEL)

MAX. PRESSURE – 95"H₂O (60 Hz), 75"H₂O (50 Hz)

MAX. VACUUM – 80"H₂O (60 Hz), 65"H₂O (50 Hz)

MAX. AIR FLOW – 520 CFM (60 Hz), 420 CFM (50 Hz)

PRODUCT FEATURES

- Rugged construction, low maintenance
- Oilless operation
- UL and CSA approved motors with permanently sealed ball bearings
- Class F insulation on motors
- Aluminum impeller; cast iron cover and housing
- Includes (2) muffler AJ121F
- Smaller and less costly than two motor-mounted units

RECOMMENDED ACCESSORIES

- Pressure gauge AE133
- Inlet Filter AJ126F (pressure), use (2)
- Vacuum gauge AE134
- Inline filter AJ151H (vacuum)
- Relief valve AG258F
- Liquid separator RMS400 (vacuum)
- Muffler AJ121H (for exhaust)



Product Dimensions (in. mm)

TOP VIEW

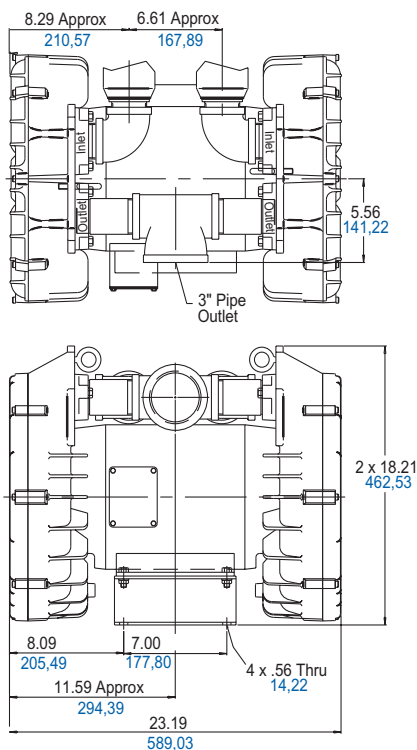

Note: Unit must be mounted with shaft horizontal.

Note: Unit is stocked with plumbing arrangement of parallel compressor. The end user may reverse intake and exhaust plumbing or tie the inlets together with 2" pipe to make a vacuum unit.

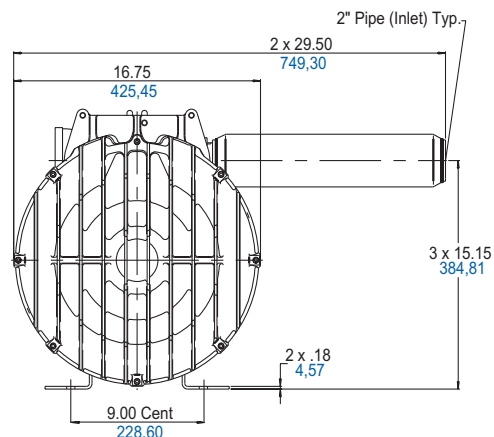

Product Specifications

MODEL NUMBER		R6PP3110M
Motor Enclosure		ODP
HP/kW	60 Hz	11/8,2
	50 Hz	7/5,2
Voltage	60 Hz	208-230/460-3
	50 Hz	220/380-415-3
Amps	60 Hz	36-35/17.5
	50 Hz	32/15.5-13
Starting Amps	60 Hz	181 @ 460V
	50 Hz	176 @ 380V
Insulation Class		F
Recommended NEMA Starter Size		2/2
Net Weight (lbs/kg)		309/140

Product Performance

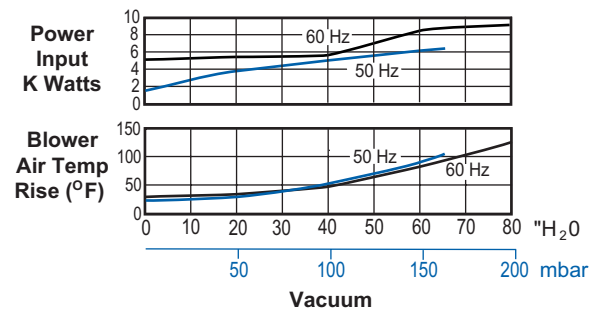
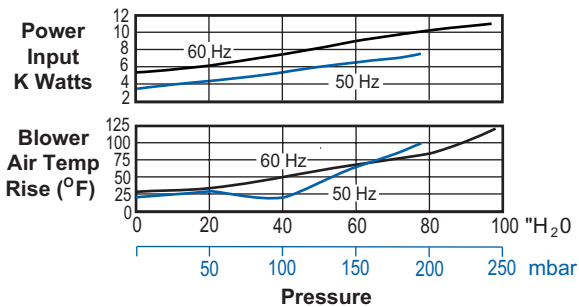
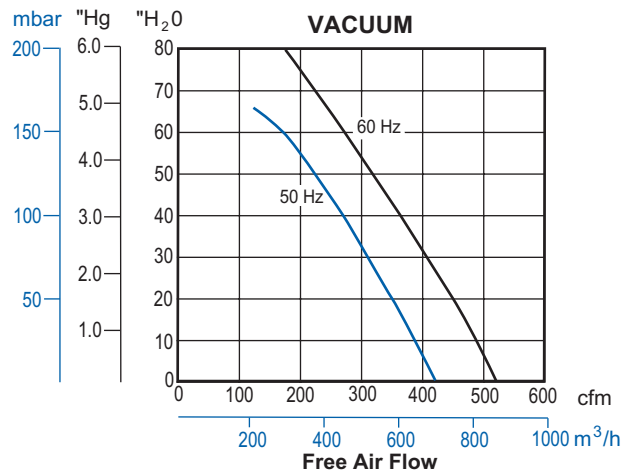
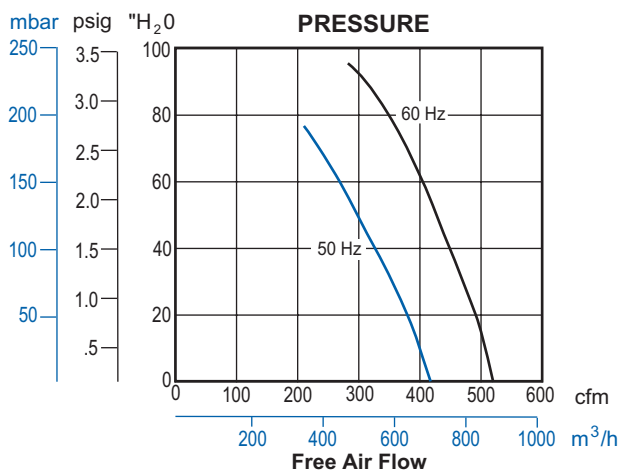



R7 SERIES

MODELS R7100A-3, R7100B-1

MAX. PRESSURE – 125" H₂O (60 Hz), 115" H₂O (50 Hz)

MAX. VACUUM – 110" H₂O (60 Hz), 90" H₂O (50 Hz)

MAX. AIR FLOW – 420 CFM (60 Hz), 350 CFM (50 Hz)

PRODUCT FEATURES

- Rugged construction, low maintenance
- Oilless operation
- UL and CSA approved TEFC motors with permanently sealed ball bearings
- IP54 rated enclosure on motors
- Aluminum impeller; cast iron cover and housing
- Can be mounted in any plane
- Inlet and outlet have internal muffling

RECOMMENDED ACCESSORIES

- Pressure gauge AE133A
- Inlet filter AJ126G (pressure)
- Vacuum gauge AE134
- Vacuum gauge for monitoring inlet filter restriction AJ497
- Pressure/vacuum relief valve AG258
- Silencer for vacuum relief valve AJ121D
- Inline filter AJ151H (vacuum)
- External muffler for additional silencing AJ121G
- Liquid separator RMS400 (vacuum)
- Foam replacement kit K827

Product Dimensions (in. mm)

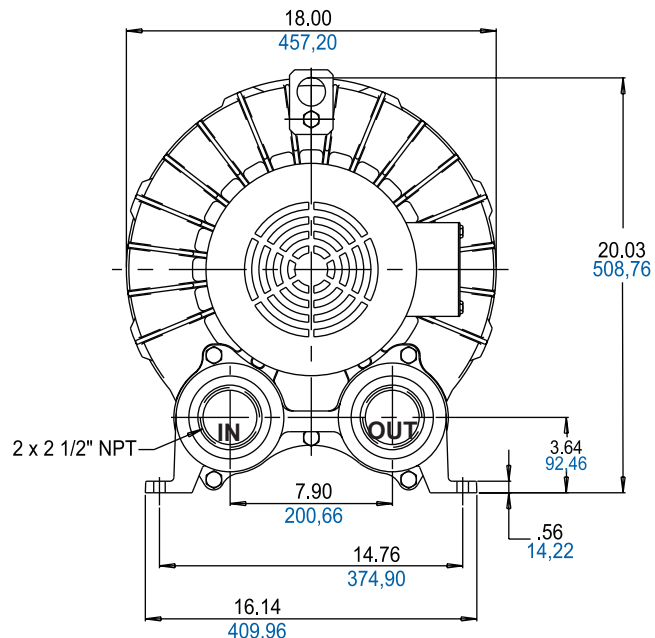
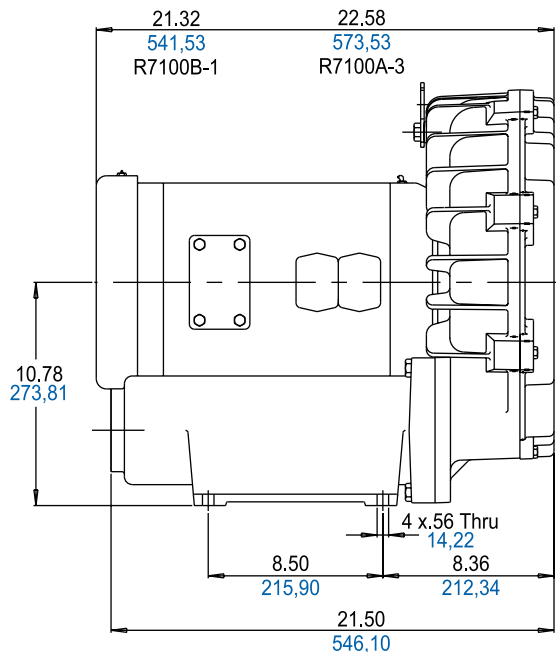

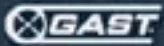

Product Specifications

MODEL NUMBER		R7100A-3	R7100B-1
Motor Enclosure		TEFC	TEFC
HP/kW	60 Hz	10/7,5	10/7,5
	50 Hz	8/6	-
Voltage	60 Hz	208-230/460-3	575-3
	50 Hz	190-220/380-440-3	-
Amps	60 Hz	35-29.5/15	9.6
	50 Hz	27-23/13.5-12.3	-
Starting Amps	60 Hz	120 @ 460V	84 @ 575V
	50 Hz	143 @ 380V	-
Insulation Class		F	F
Recommended NEMA Starter Size		2/1	1
Net Weight (lbs/kg)		293/133	290/131

Product Performance

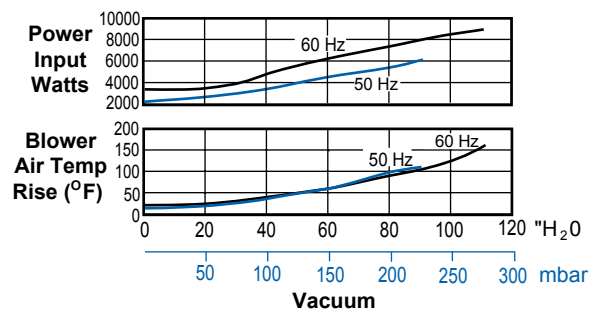
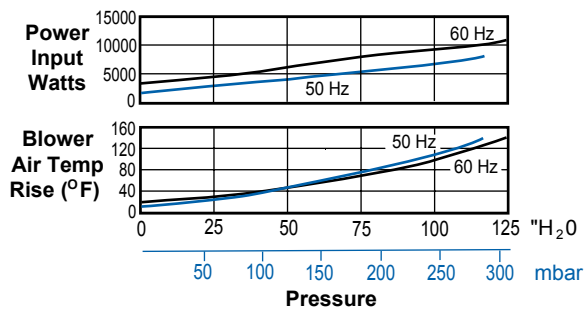
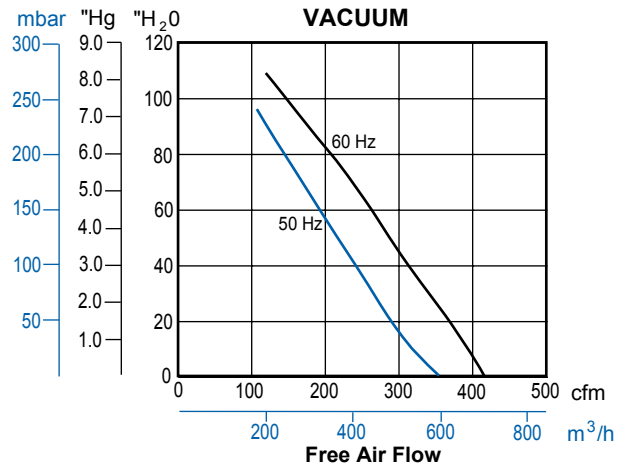
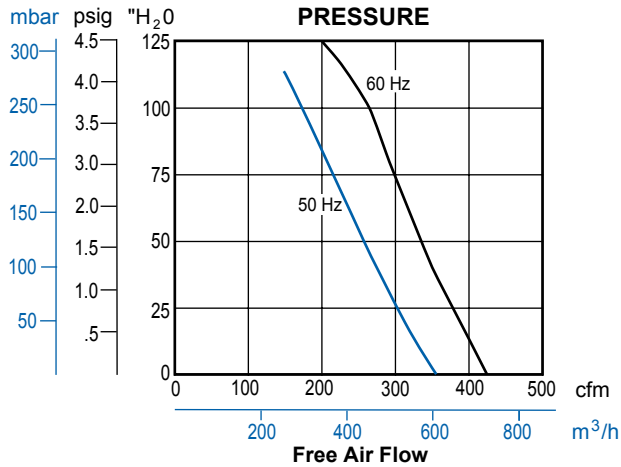



R7P SERIES

MODEL R7P3180M (PARALLEL)

MAX. PRESSURE – 105" H₂O (60 Hz), 90" H₂O (50 Hz)

MAX. VACUUM – 95" H₂O (60 Hz), 85" H₂O (50 Hz)

MAX. AIR FLOW – 795 CFM (60 Hz), 666 CFM (50 Hz)

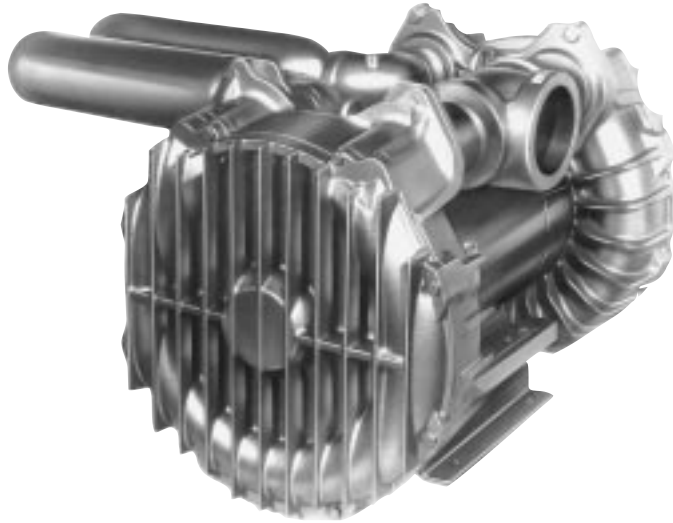

PRODUCT FEATURES

- Rugged construction, low maintenance
- Oilless operation
- UL and CSA approved motor with permanently sealed ball bearings
- Cast iron blower housing and cover. Cast aluminum impeller
- Smaller and less costly than two blowers
- Includes external mufflers for additional silencing AJ121M (2)

RECOMMENDED ACCESSORIES

- Pressure gauge AE133
- Two inlet filters AJ126G (pressure)
- Vacuum gauge AE134
- Vacuum gauge for monitoring inlet filter restriction AJ497
- Pressure/vacuum relief valve AG258F
- Silencer for vacuum relief valve AJ121G
- Inline filter AJ151M (vacuum)
- Liquid separator RMS400 (for vacuum line)

Product Dimensions (in. mm)

Note: Unit must be mounted with shaft horizontal.

Note: Unit is stocked with plumbing arrangement of parallel compressor. The end user may reverse intake and exhaust plumbing to make a vacuum unit.

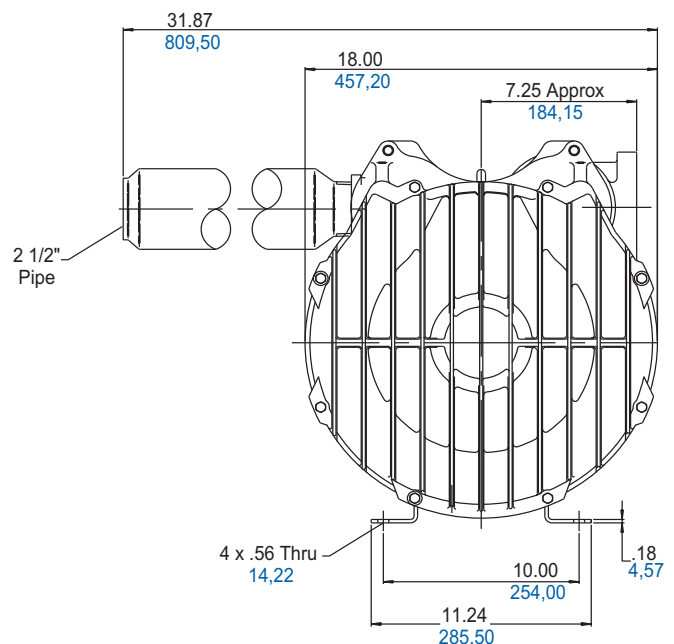
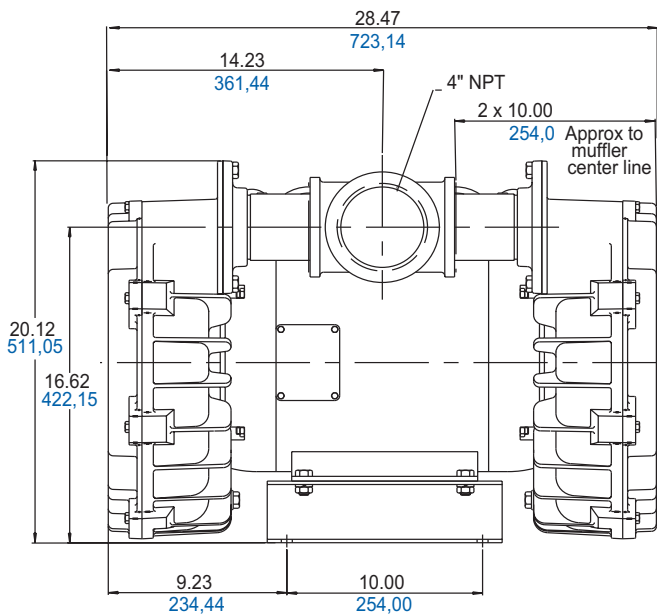

Product Specifications

MODEL NUMBER		R7P3180M
Motor Enclosure		ODP
HP/kW	60 Hz	18/13,4
	50 Hz	12/9
Voltage	60 Hz	230/460-3
	50 Hz	190-220/380-440-3
Amps	60 Hz	52/26
	50 Hz	52-45/26-23
Starting Amps	60 Hz	238 @ 460V
	50 Hz	Consult Factory
Insulation Class		F
Recommended NEMA Starter Size		3/2
Net Weight (lbs/kg)		438/198

Product Performance

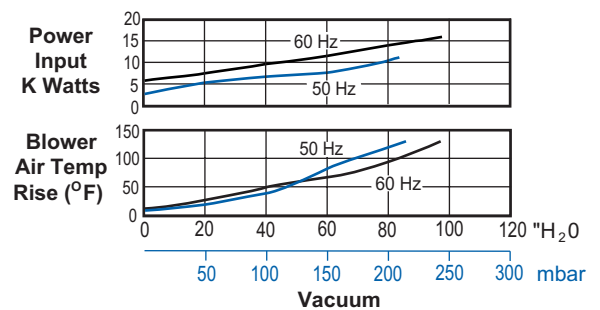
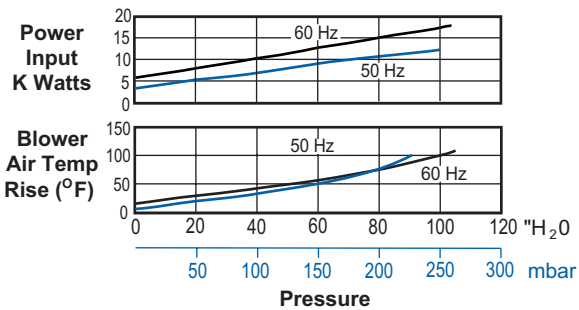
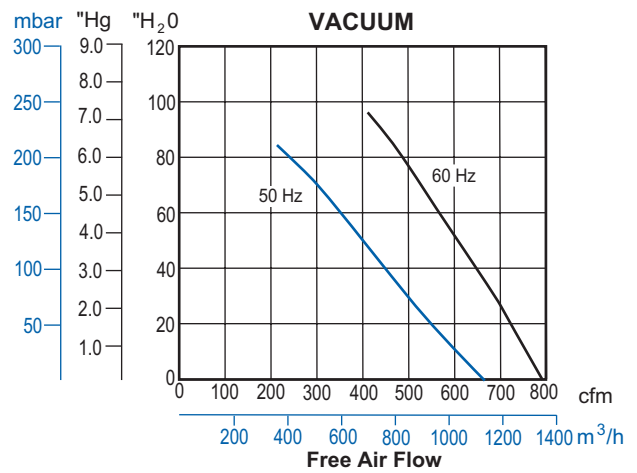
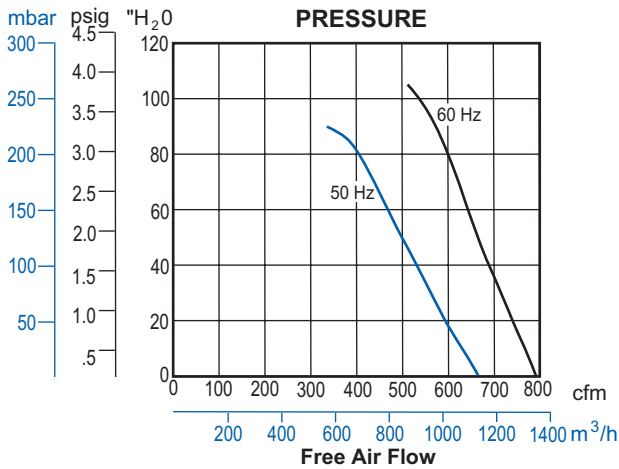



R9 SERIES
MODEL R93150A

MAX. PRESSURE – 125" H₂O (60 Hz), 125" H₂O (50 Hz)

MAX. VACUUM – 115" H₂O (60 Hz), 105" H₂O (50 Hz)

MAX. AIR FLOW – 680 CFM (60 Hz), 585 CFM (50 Hz)



PRODUCT FEATURES

- Rugged construction, low maintenance
- Oilless operation
- UL and CSA approved TEFC motor with permanently sealed ball bearings
- IP54 rated enclosure on motors
- Cast iron housing, cover and muffler enclosure. Cast aluminum impeller
- Inlet and outlet have internal muffling

RECOMMENDED ACCESSORIES

- Pressure gauge AE133
- Inlet filter AJ126M (pressure)
- Vacuum gauge AE134
- Vacuum gauge for monitoring inlet filter restriction AJ497
- Pressure/vacuum relief valve AG258F
- Silencer for vacuum relief valve AJ121G
- Inline filter AJ151M (vacuum)
- External muffler for additional silencing AJ121H
- Foam replacement kit K829

Product Dimensions (in. mm)

Note: Unit must be mounted with shaft horizontal.

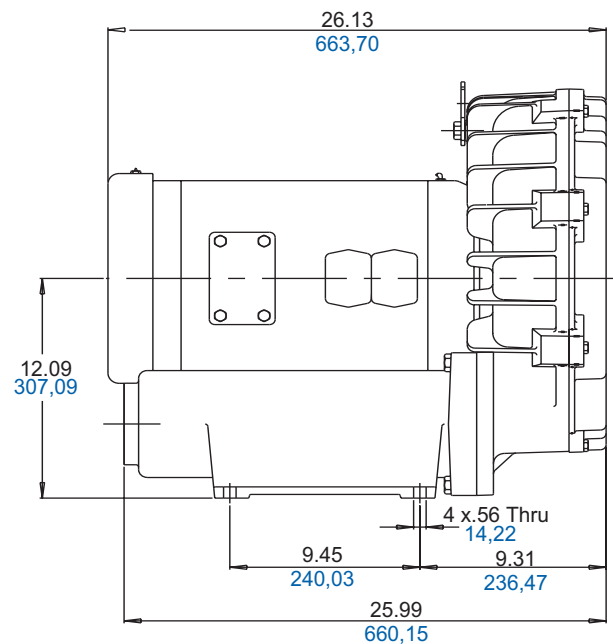
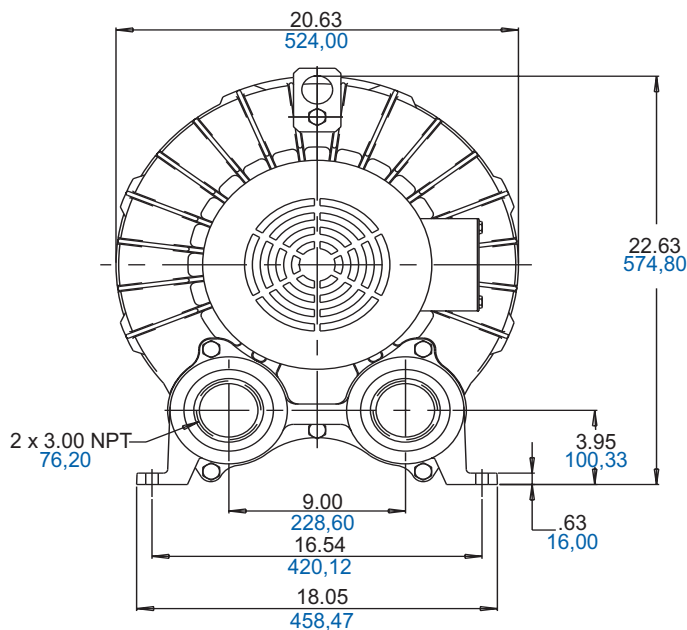

Product Specifications

MODEL NUMBER		R93150A
Motor Enclosure		TEFC
HP/kW	60 Hz	15/11,1
	50 Hz	10/7,5
Voltage	60 Hz	208-230/460-3
	50 Hz	190-220/380-440-3
Amps	60 Hz	50-50/25
	50 Hz	46-42/23-21
Starting Amps	60 Hz	173 @ 460V
	50 Hz	185 @ 440V
Insulation Class		F
Recommended NEMA Starter Size		2/2
Net Weight (lbs/kg)		452/204

Product Performance

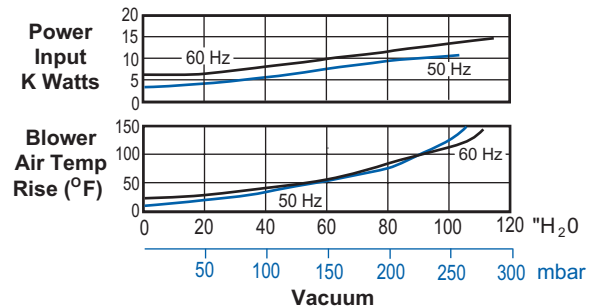
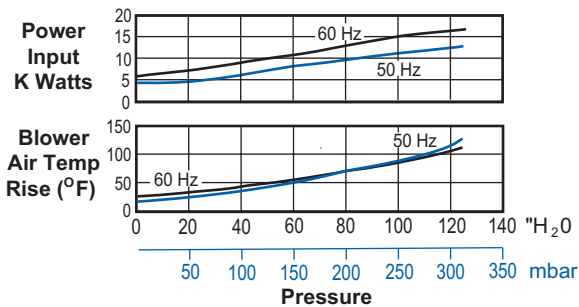
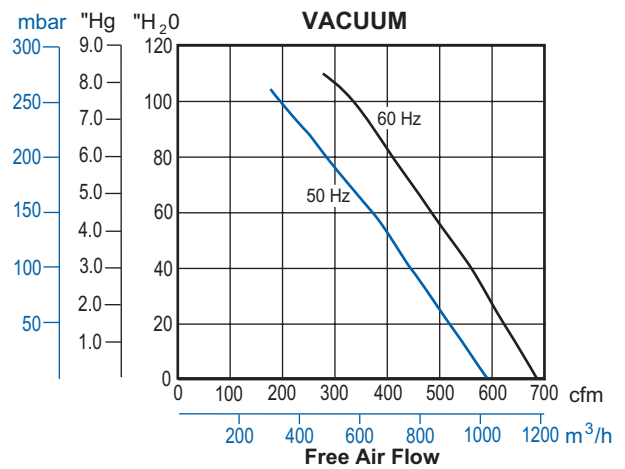
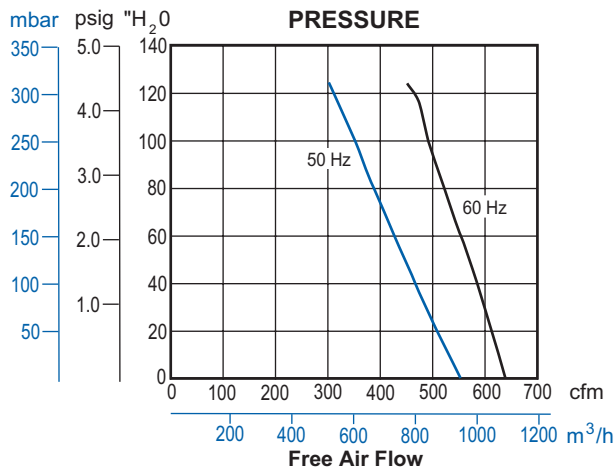



R9P SERIES
MODEL R9P3300M

MAX. PRESSURE – 125" H₂O (60 Hz), 110" H₂O (50 Hz)
MAX. VACUUM – 110" H₂O (60 Hz), 100" H₂O (50 Hz)
MAX. AIR FLOW – 1350 CFM (60 Hz), 1140 CFM (50 Hz)



PRODUCT FEATURES

- Rugged construction, low maintenance
- Oilless operation
- UL and CSA approved ODP motor with permanently sealed ball bearings
- Cast iron blower housing and covers. Cast aluminum impellers
- Smaller and less costly than two motor-mounted units
- Includes external mufflers for additional silencing AJ121H (2)

RECOMMENDED ACCESSORIES

- Pressure gauge AE133
- Two inlet filters AJ126M (pressure)
- Vacuum gauge AE134
- Vacuum gauge for monitoring inlet filter restriction AJ497
- Two pressure/vacuum relief valves AG258F mounted in customer supplied plumbing
- Silencer for each vacuum relief valve AJ121G
- External muffler for additional silencing AJ121N
- Two inline filters (vacuum) AJ151M mounted in parallel in customer provided plumbing

Product Dimensions (in. mm)

Note: Unit must be mounted with shaft horizontal.

Note: Unit is stocked with plumbing arrangement of parallel compressor.
 End user may reverse intake and exhaust plumbing to make a vacuum unit.

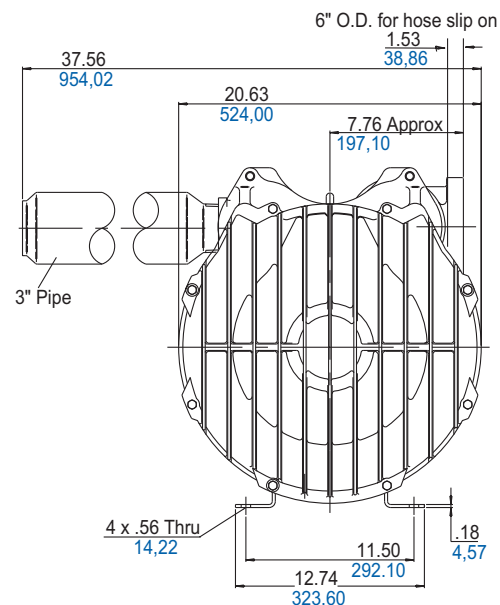
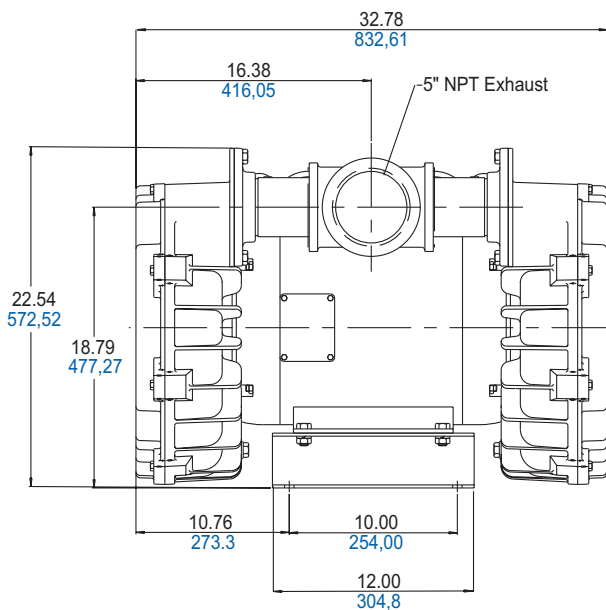

Product Specifications

MODEL NUMBER		R9P3300M
Motor Enclosure		ODP
HP/kW	60 Hz	30/22,3
	50 Hz	19/14,1
Voltage	60 Hz	230/460-3
	50 Hz	190-220/380-440-3
Amps	60 Hz	78/39
	50 Hz	76-70/38-35
Starting Amps	60 Hz	280 @ 460V
	50 Hz	185 @ 440V
Insulation Class		F
Recommended NEMA Starter Size		3/3
Net Weight (lbs/kg)		622/327

Product Performance

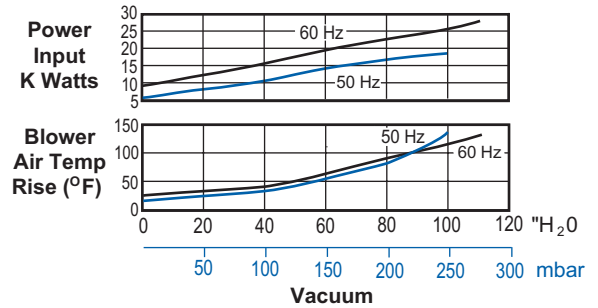
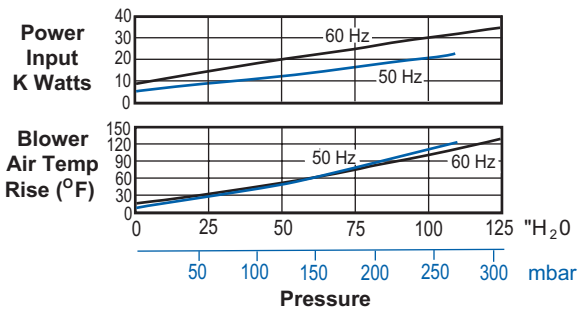
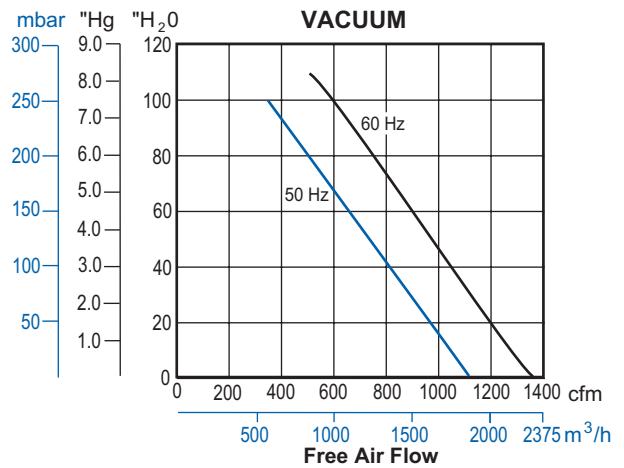
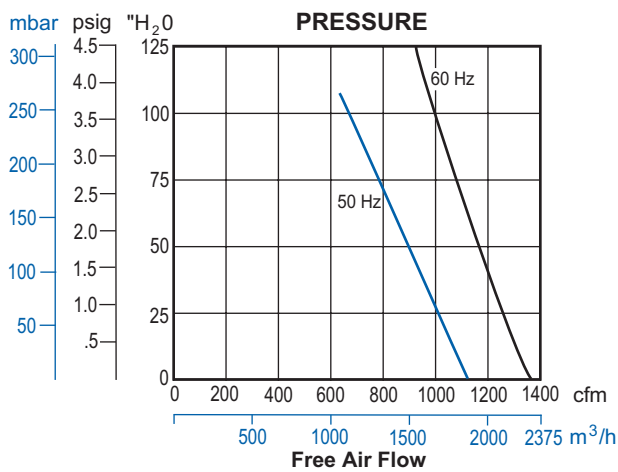



High Pressure Models



R4H SERIES

MODELS R4H3060A

MAX. PRESSURE – 284" H₂O (60 Hz), 284" H₂O (50 Hz)

MAX. VACUUM – 183" H₂O (60 Hz), 183" H₂O (50 Hz)

MAX. AIR FLOW – 128 CFM (60 Hz), 107 CFM (50 Hz)

PRODUCT FEATURES

- Rugged construction, low maintenance
- Oilless operation
- UL and CSA approved TEFC motor with permanently sealed ball bearings
- IP54 rated enclosure on motors
- Cast aluminum dual impeller, blower housing and cover
- Can be mounted in any plane
- Inlet and outlet have internal muffling

RECOMMENDED ACCESSORIES

- Pressure gauge AE133F
- Inlet filter AJ126D (pressure)
- Pressure relief valve PV102 (60Hz), PV098 (50Hz)
- Vacuum gauge AE134F
- Vacuum gauge for monitoring inlet filter restriction AJ497
- Vacuum relief valve AG258
- Silencer for vacuum relief valve AJ121D
- Inline filter AJ151E (vacuum)
- External muffler for additional silencing AJ121F
- Foam replacement kit K905

Product Dimensions (in. mm)

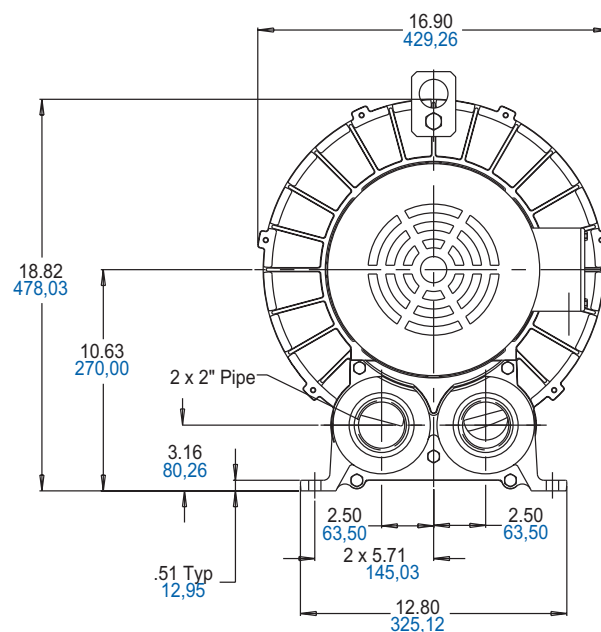
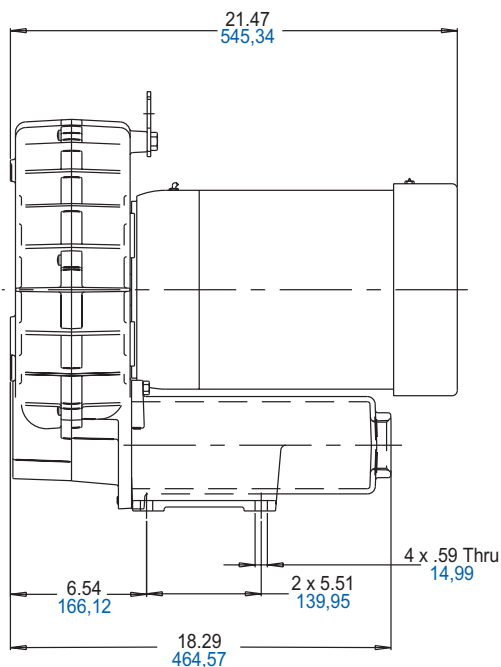

Product Specifications

MODEL NUMBER		R4H3060A	R4H3060B
Motor Enclosure		TEFC	TEFC
HP/kW	60 Hz	6/4.4	6/4.4
	50 Hz	5/3.7	-
Voltage	60 Hz	208-230/460-3	575-3
	50 Hz	190-220/380-440-3	-
Amps	60 Hz	19.5-18.2/9.1	7.3
	50 Hz	16.8-16.0/8.4-8.0	-
Starting Amps	60 Hz	83 @ 460V	67 @ 575V
	50 Hz	72 @ 380V	-
Insulation Class		F	F
Recommended NEMA Starter Size		1/0	0
Net Weight (lbs/kg)		200/91	200/91

Product Performance

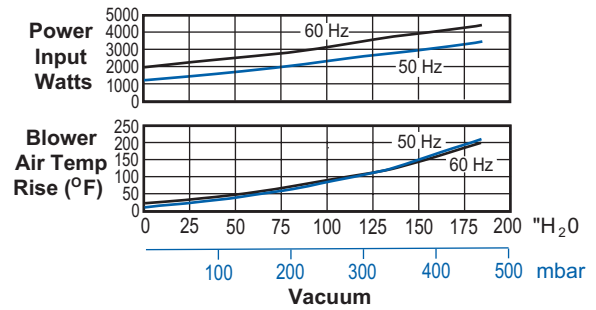
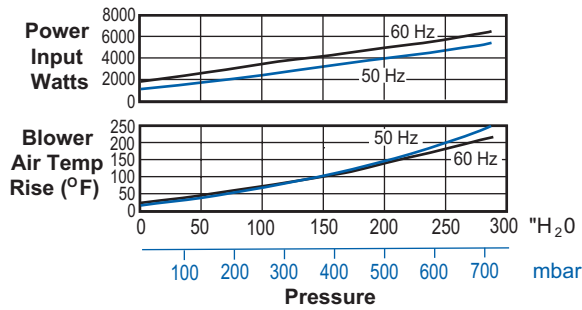
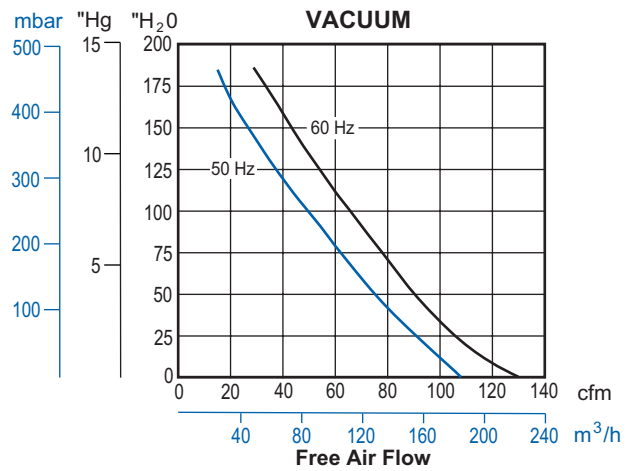
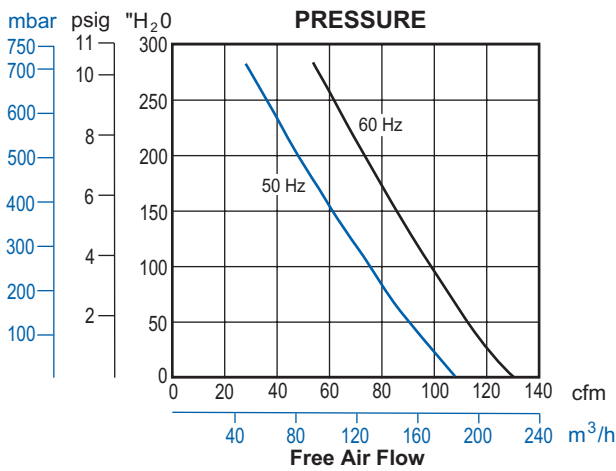



HIGH PRESSURE MODELS



R4H SERIES

MODEL R4H3060A-1 (VACUUM ONLY)

MAX. VACUUM – 204" H₂O (60 Hz), 176" H₂O (50 Hz)

MAX. AIR FLOW – 121 CFM (60 Hz), 101 CFM (50 Hz)

PRODUCT FEATURES

- Rugged construction, low maintenance
- Oilless operation
- UL and CSA approved TEFC motor with permanently sealed ball bearings
- IP54 rated enclosure on motors
- Cast aluminum dual impeller, blower housing and cover
- Can be mounted in any plane
- Inlet and outlet have internal muffling

RECOMMENDED ACCESSORIES

- Vacuum gauge AE134F
- Vacuum relief valve AG258
- Silencer for vacuum relief valve AJ121D
- Inline filter AJ151E (vacuum)
- External muffler for additional silencing AJ121F

Product Dimensions (in. mm)

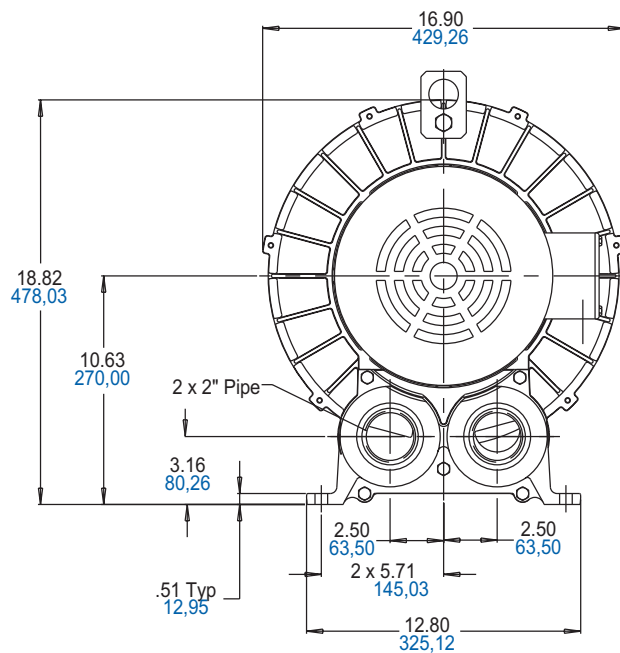
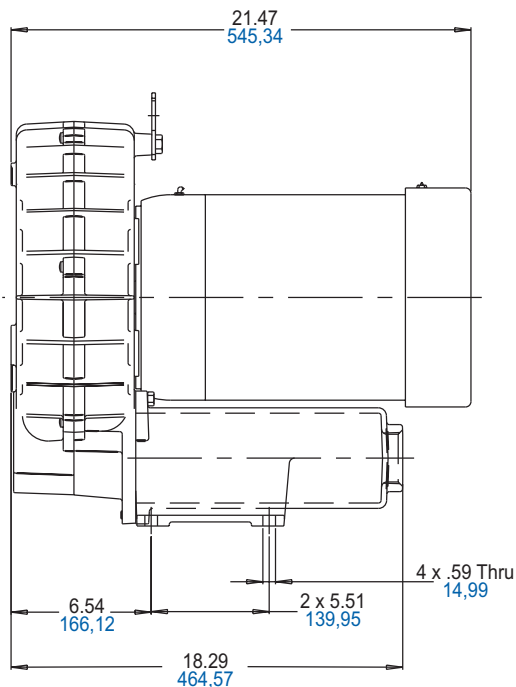

Product Specifications

MODEL NUMBER		R4H3060A-1
Motor Enclosure		TEFC
HP/kW	60 Hz	6/4,5
	50 Hz	5/3,7
Voltage	60 Hz	208-230/460-3
	50 Hz	190-220/380-440-3
Amps	60 Hz	19.5-18.2/9.1
	50 Hz	16.8-16.0/8.4-8.0
Starting Amps	60 Hz	83 @ 460V
	50 Hz	72 @ 380V
Insulation Class		F
Recommended NEMA Starter Size		1/0
Net Weight (lbs/kg)		200/91

Product Performance

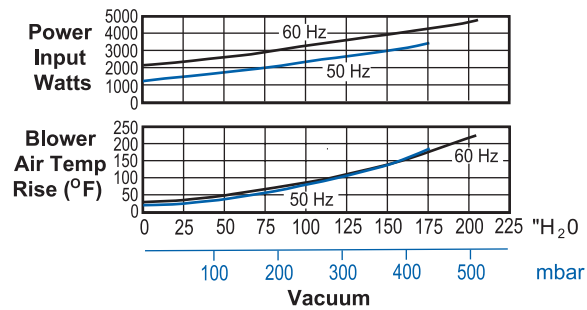
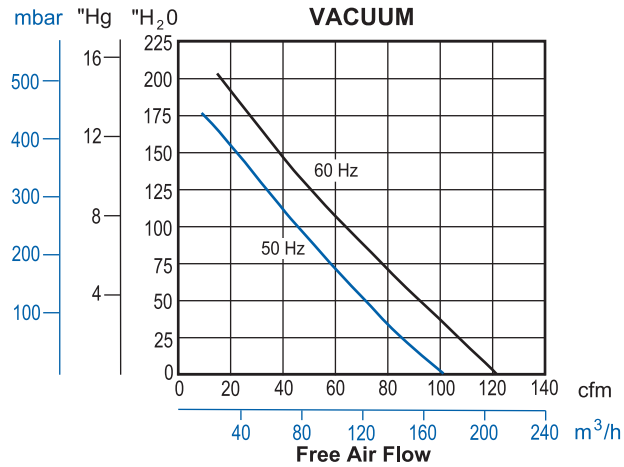



High Pressure Models

R6PS SERIES

MODEL R6PS3110M (STAGED)

MAX. PRESSURE – 170"H₂O (60 Hz), 145"H₂O (50 Hz)

MAX. VACUUM – 130"H₂O (60 Hz), 110"H₂O (50 Hz)

MAX. AIR FLOW – 280 CFM (60 Hz), 230 CFM (50 Hz)



PRODUCT FEATURES

- Rugged construction, low maintenance
- Oilless operation
- UL and CSA approved motor with permanently sealed ball bearings
- Aluminum impeller; cast iron cover and housing
- Includes muffler AJ121F
- Smaller and less costly than two motor-mounted units

RECOMMENDED ACCESSORIES

- Pressure gauge AE133A
- Inlet filter AJ126F (pressure)
- Vacuum gauge AE134
- Inline filter AJ151H (vacuum)
- Relief valve AG258
- Liquid separator RMS300 (vacuum)

Product Dimensions (in. mm)

Note: Unit must be mounted with shaft horizontal.

TOP VIEW

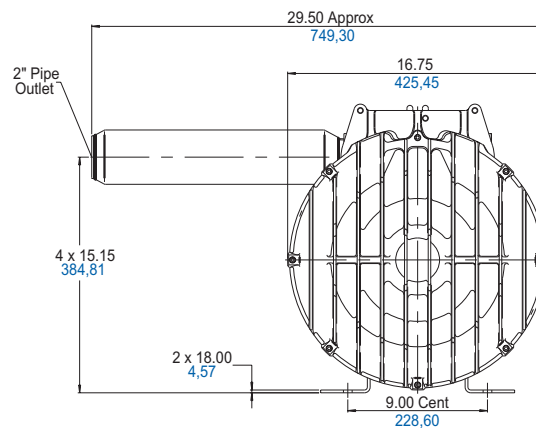
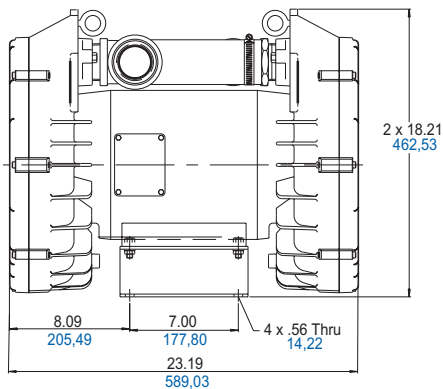
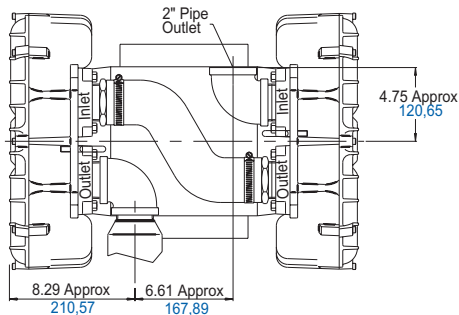

Product Specifications

MODEL NUMBER		R6PS3110M
Motor Enclosure		OPEN
HP/kW	60 Hz	11/8,2
	50 Hz	7/5,2
Voltage	60 Hz	208-230/460-3
	50 Hz	220/380-415-3
Amps	60 Hz	36-35/17.5
	50 Hz	32/15.5-13
Starting Amps	60 Hz	181 @ 460V
	50 Hz	176 @ 380V
Insulation Class		F
Recommended NEMA Starter Size		2/2
Net Weight (lbs/kg)		309/140

Product Performance

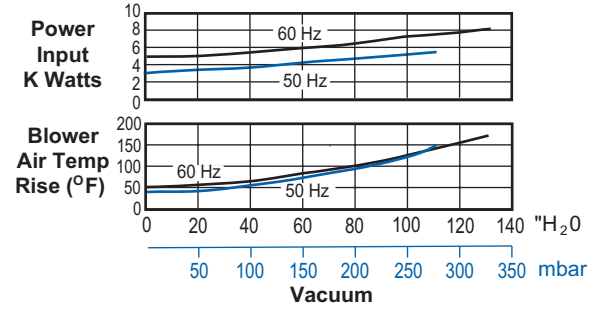
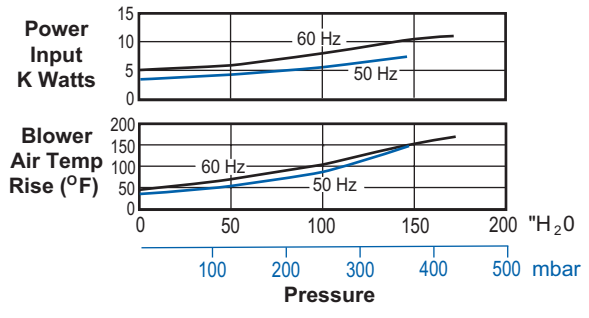
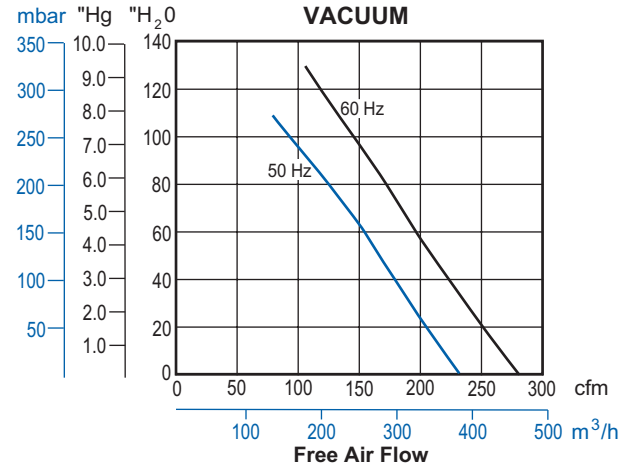
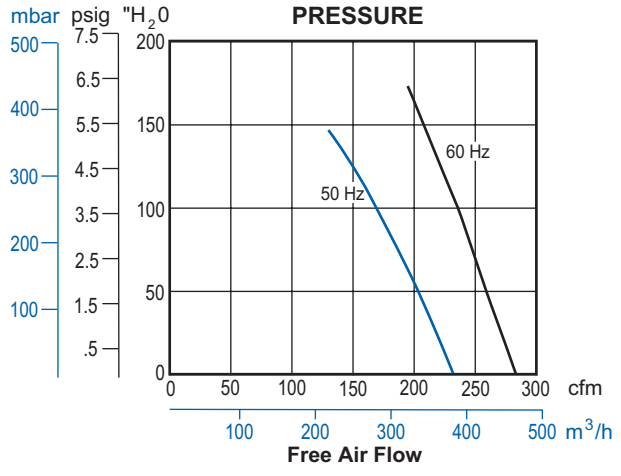



HIGH PRESSURE MODELS

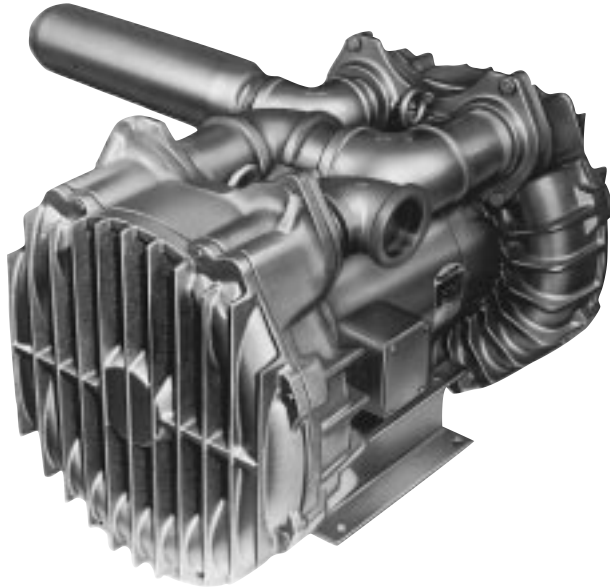

R7S SERIES

MODEL R7S3180M (STAGED)

MAX. PRESSURE – 200" H₂O (60 Hz), 170" H₂O (50 Hz)

MAX. VACUUM – 150" H₂O (60 Hz), 130" H₂O (50 Hz)

MAX. AIR FLOW – 430 CFM (60 Hz), 350 CFM (50 Hz)

PRODUCT FEATURES.

- Rugged construction, low maintenance
- Oilless operation
- UL and CSA approved motor with permanently sealed ball bearings
- Cast iron blower housing and cover. Cast aluminum impeller
- Includes external muffler for additional silencing AJ121G

RECOMMENDED ACCESSORIES

- Pressure gauge AE133A
- Inlet filter AJ126G (pressure)
- Vacuum gauge AE134
- Vacuum gauge for monitoring inlet filter restriction AJ497
- Pressure/vacuum relief valve AG258F
- Silencer for vacuum relief valve AJ121G
- Inline filter AJ151H (vacuum)
- Liquid separator RMS400 (for vacuum line)

Product Dimensions (in. mm)

Note: Unit must be mounted with shaft horizontal

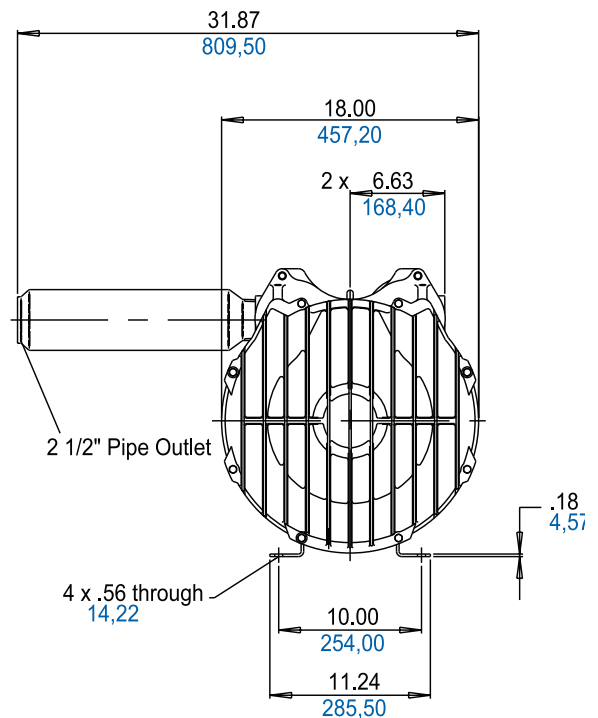
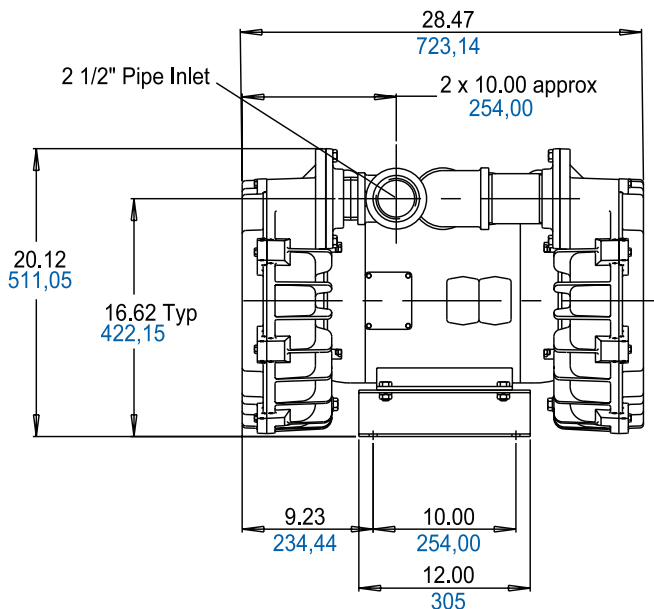

Product Specifications

MODEL NUMBER		R7S3180M
Motor Enclosure		ODP
HP/kW	60 Hz	18/13,4
	50 Hz	12/9
Voltage	60 Hz	230/460-3
	50 Hz	190-220/380-440-3
Amps	60 Hz	52/26
	50 Hz	52-45/26-23
Starting Amps	60 Hz	238 @ 460V
	50 Hz	Consult Factory
Insulation Class		F
Recommended NEMA Starter Size		3/2
Net Weight (lbs/kg)		431/195,7

Product Performance

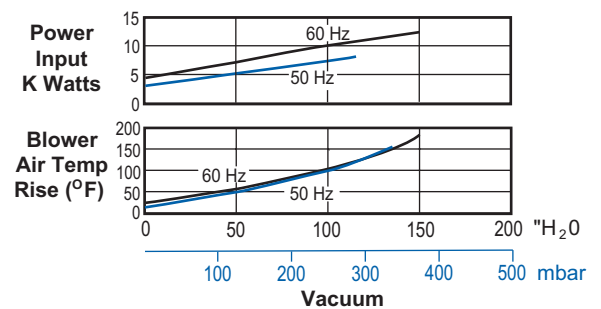
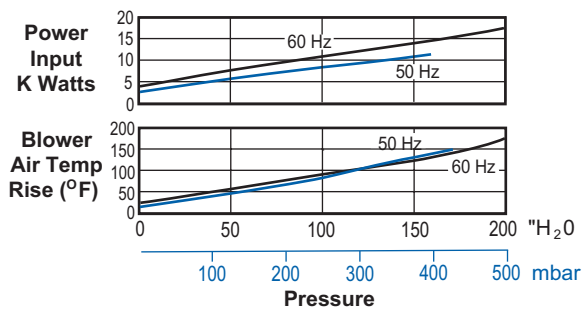
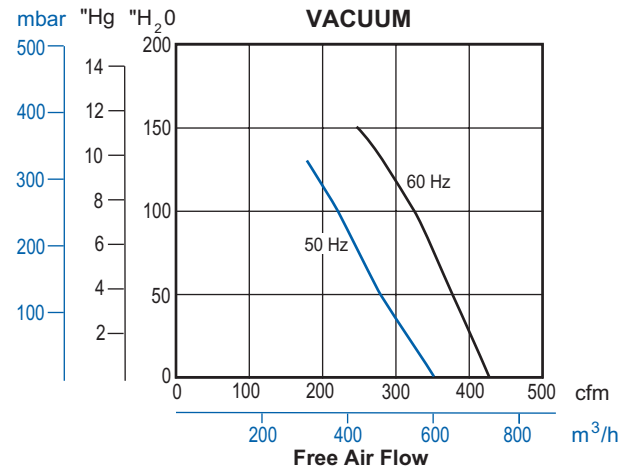
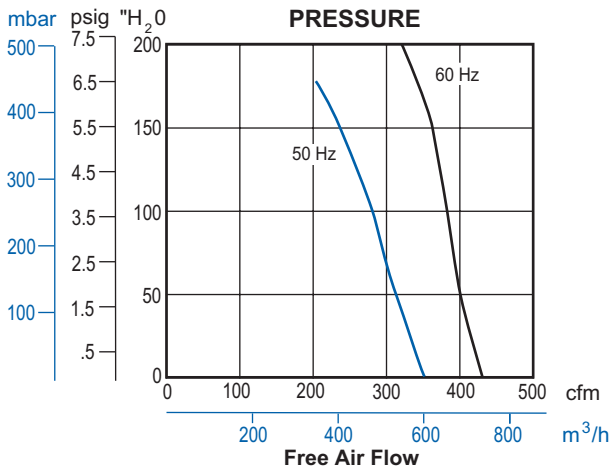



High Pressure Models

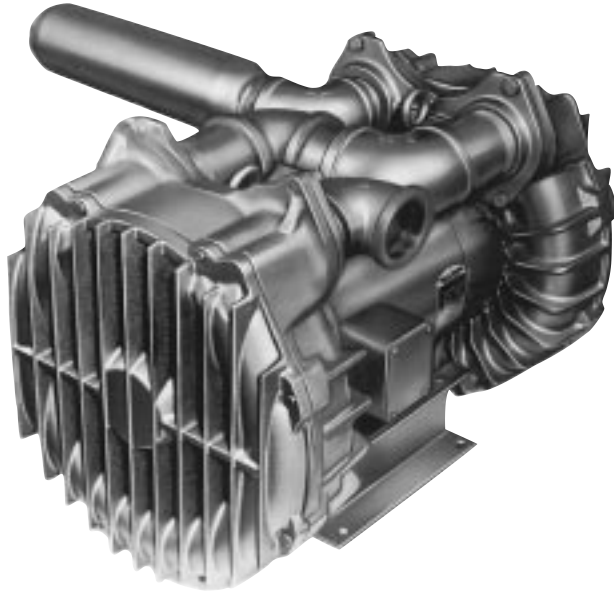

R9S SERIES MODEL R9S3300M

MAX. PRESSURE – 222" H₂O (60 Hz), 208" H₂O (50 Hz)

MAX. VACUUM – 149" H₂O (60 Hz), 142" H₂O (50 Hz)

MAX. AIR FLOW – 660 CFM (60 Hz), 585 CFM (50 Hz)

PRODUCT FEATURES

- Rugged construction, low maintenance
- Oilless operation
- UL and CSA approved motor with permanently sealed ball bearings
- Cast iron housing, cover and muffler enclosure.
- Cast aluminum impeller
- External muffler for additional silencing AJ121H
- Smaller and less costly than two motor-mounted units

RECOMMENDED ACCESSORIES

- Pressure gauge AE133F
- Inlet filter AJ126M (pressure)
- Vacuum gauge AE134
- Vacuum gauge for monitoring inlet filter restriction AJ497
- Pressure/vacuum relief valve AG258F
- Silencer for vacuum relief valve AJ121G
- Inline filter AJ151M (vacuum)

Product Dimensions (in. mm)

Note: Unit must be mounted with shaft horizontal

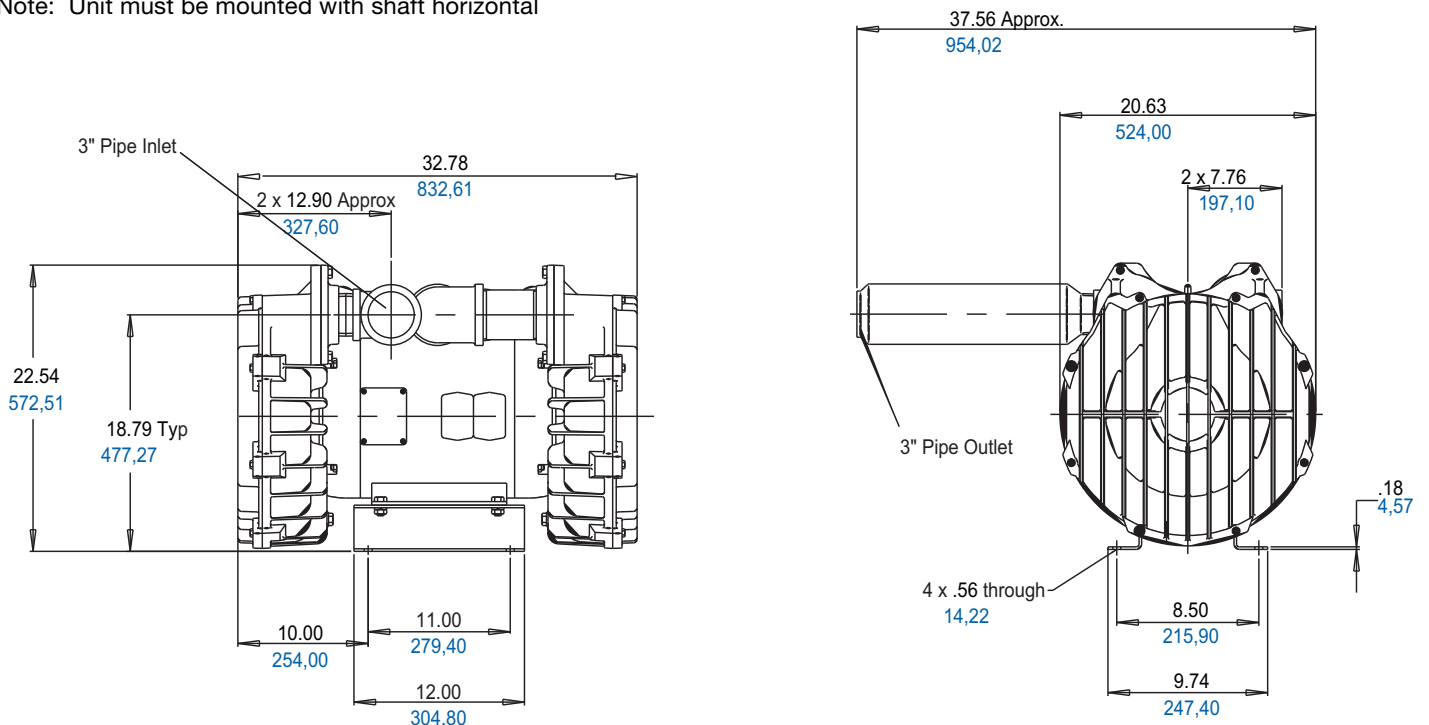

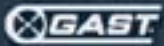

Product Specifications

MODEL NUMBER		R9S3300M
Motor Enclosure		ODP
HP/kW	60 Hz	30/22,3
	50 Hz	19/14,3
Voltage	60 Hz	230/460-3
	50 Hz	190-220/380-440-3
Amps	60 Hz	98/49
	50 Hz	82-47/41-39
Starting Amps	60 Hz	320 @ 460V
	50 Hz	308 @ 440V
Insulation Class		F
Recommended NEMA Starter Size		3/3
Net Weight (lbs/kg)		606,275

Product Performance

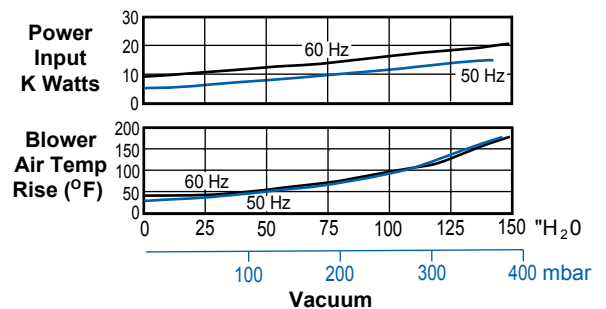
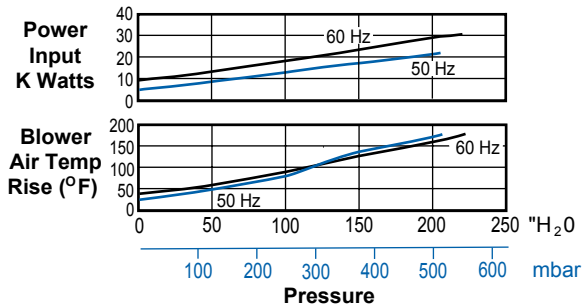
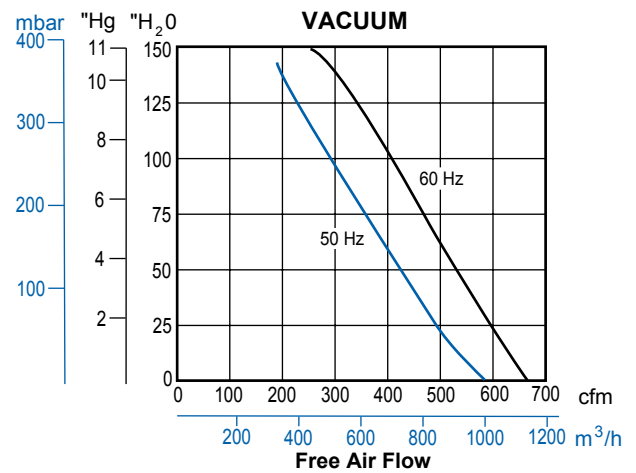
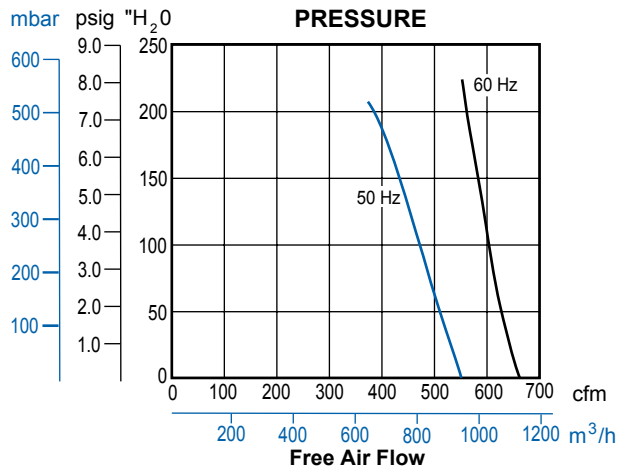

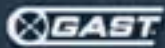

R3-R7 SERIES - EXPLOSION PROOF MOTORS



R3105N-50



R4 - R7 Series

MODELS	Maximum Pressure ("H ₂ O)		Maximum Vacuum ("H ₂ O)		Maximum Air Flow (CFM)	
	60 Hz	50 Hz	60 Hz	50 Hz	60 Hz	50 Hz
R3105N-50	43	31	40	28	53	44
R4110N-50 R4310P-50	51	38	48	35	92	74
R4P115N-50	65	45	60	40	133	112
R5125Q-50 R5325R-50	55 65	- 50	60 65	- 47	160 160	- 133
R6130Q-50 R6340R-50	60 100	75 75	70 80	65 65	215 215	180 180
R6P155Q-50 R6P355R-50	95 100	80 80	85 85	65 65	280 280	235 232
R7100R-50	100	90	110	85	425	350

PRODUCT FEATURES

- Rugged design, maintenance free
- Quiet operation within OSHA standards
- Blowers and motors rated for continuous duty
- UL and CSA approved multi-voltage motors, incorporating approved thermal protection
- Motors classified as Explosion Proof Division 1 and 2, for Group D explosive atmospheres
- Motors carry full rated load at temperatures below Class B motor insulation limits
- Class F motor insulation used in motors larger than 1 HP
- Motors conform to NEMA frame sizes; motor enclosures conform to IP54 (suitable for outdoor use)
- Pilot duty thermal overload protection is standard on all 1 HP and larger motors
- Double sealed motor ball bearings with a B10 life exceeding 30,000 hours of continuous operation at the maximum rated continuous blower load
- Sealed air streams
- Aluminum impeller, housing and cover; viton shaft seal.
- Pressurized and leak-tested to less than 5cc/minute

Recommended Accessories	R3 Series	R4 Series	R4P Series	R5 Series	R6 Series	R6P Series	R7 Series
Pressure Gauge	AJ496	AJ496	AE133	AE133	AE133	AE133	AE133
Vacuum Gauge	AJ497	AJ497	AE134	AE134	AE134	AE134	AE134
Pressure Filter	AJ126C	AJ126D	AJ126D	AJ126D	AJ126F	AJ126F	AJ126G
Vacuum Filter (Inline)	AJ151C	AJ151D	AJ151D	AJ151E	AJ151G	AJ151G	AJ151H



Product Dimensions (in. mm)

Model R3

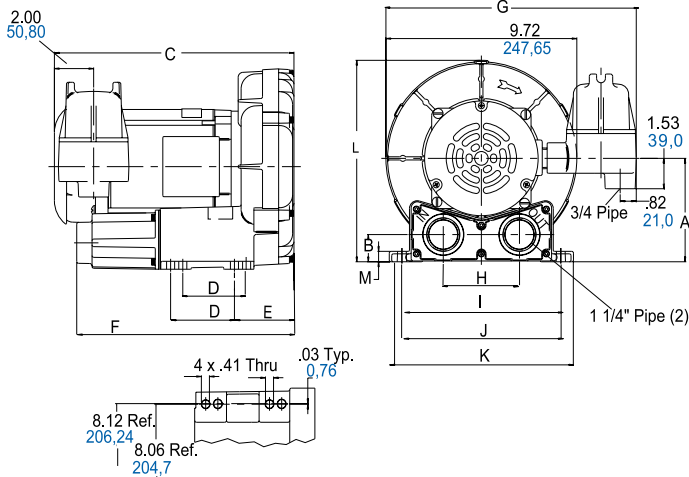

Models R6P, R7

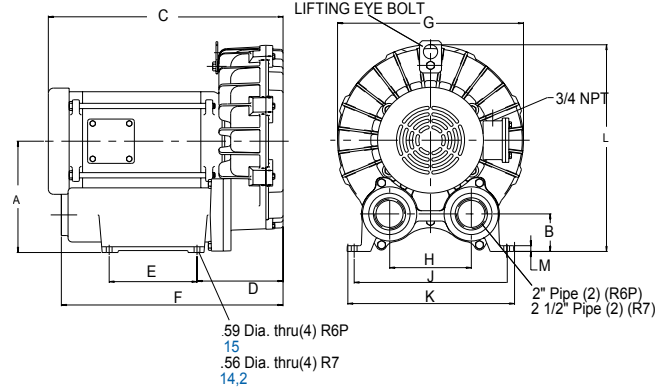

Models R4, R4P, R5, R6

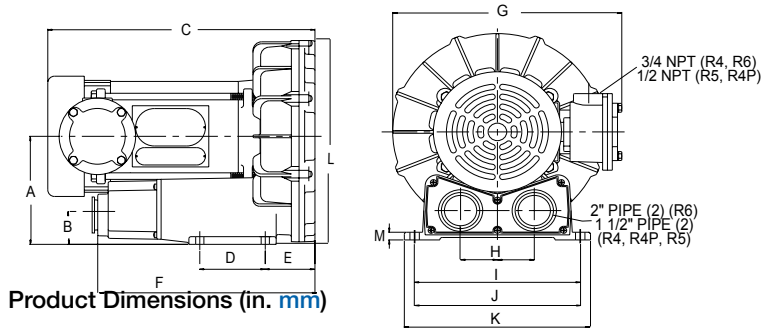

Mounting Hole Detail

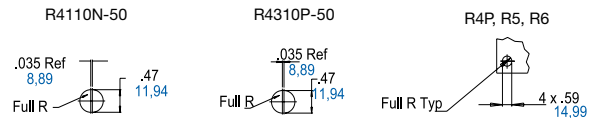

Product Dimensions (in. mm)

Model	A	B	C	D	E	F	G	H	I	J	K	L	M
R3105N-50	5.21 132	1.37 35	12.3 312	3.25 83	3.06 78	11.06 281	12.75 324	3.88 99	8.06 205	8.12 206	9.38 238	10.15 258	.53 13
R4110N-50	6.18 157	1.68 43	15.34 390	3.75 95	2.85 72	12.44 316	12.34 313	3.96 101	8.86 225	8.93 227	10.00 254	11.80 300	.44 11
R4310P-50	6.18 157	1.68 43	14.09 358	3.75 95	2.84 74	12.44 316	12.34 313	3.96 101	8.86 225	8.93 227	10.00 254	11.80 300	.44 11
R4P115N-50	6.98 177	1.84 47	17.41 442	4.50 114	3.25 83	13.93 354	13.75 349	4.75 121	10.25 260	10.31 262	11.75 298	13.61 346	.60 15
R5125Q-50	7.02 178	1.82 46	17.59 447	4.50 114	3.55 90	14.22 361	13.72 348	4.75 121	10.25 260	10.31 262	11.75 298	13.80 351	.59 15
R5325R-50	7.02 178	1.82 46	16.75 425	4.50 114	3.55 90	14.22 361	13.56 344	4.75 121	10.25 260	10.31 262	11.75 298	13.80 351	.59 15
R6130Q-50	7.75 197	1.94 49	18.97 482	5.50 140	3.85 98	16.02 407	15.17 385	4.92 125	11.38 289	11.42 290	12.96 329	15.34 390	.52 13
R6340R-50	7.75 197	1.94 49	18.82 478	5.50 140	3.85 98	15.89 404	15.17 385	4.92 125	11.38 298	11.42 290	12.96 329	15.34 390	.52 13
R6P155Q-50	9.77 248	3.15 80	22.81 579	5.12 130	5.51 140	16.85 428	16.75 425	5.00 127	- -	11.42 290	12.80 325	18.14 461	.50 13
R6P355R-50	9.77 248	3.15 80	19.92 506	5.12 130	5.51 140	16.85 428	16.75 425	5.00 127	- -	11.42 290	12.80 325	18.14 461	.50 13
R7100R-50	10.79 274	3.64 92	22.77 578	8.36 212	8.50 216	21.50 546	18.00 457	7.90 201	- -	14.76 375	16.14 410	20.03 509	.56 14

Notice: Specifications subject to change without notice.



Product Specifications

MODEL NUMBER		R3105N-50	R4110N-50	R4310P-50	R4P115N-50
Motor Enclosure		XPFC	XPFC	XPFC	XPFC
HP/kW	60 Hz	.50/0,37	1.0/0,75	1.0/0,75	1.5/1,1
	50 Hz	.33/0,25	.60/0,45	.60/0,45	1.0/0,75
Voltage	60 Hz	115/208-230-1	115/208-230-1	208-230/460-3	115/208-230-1
	50 Hz	110/220-240-1	110/220-240-1	220/380-3	110/220-240-1
Amps	60 Hz	5.2/2.9-2.6	11.4/6.2-5.6	3.4-3.3/1.6	20.3/11.2-10.6
	50 Hz	4.8/2.4-2.2	9.2/5.2-4.6	3.2/1.6	15.2/7.6-8
Starting Amps	60 Hz	12.5 @ 230V	36.5 @ 230V	19.7 @ 230V	60.6 @ 230V
	50 Hz	13 @ 220V	40.6 @ 240V	23.3 @ 220V	Consult Factory
Insulation Class		B	B	B	F
Recommended NEMA Starter Size		00/00	0/00	0/0	1/0
Net Weight (lbs/kg)		52/24	60/28	58/27	79/36

MODEL NUMBER		R5125Q-50	R5325R-50	R6130Q-50	R6340R-50
Motor Enclosure		XPFC	XPFC	XPFC	XPFC
HP/kW	60 Hz	2.0/1,5	2.0/1,5	3.0/2,2	4.0/3,0
	50 Hz	-	1.5/1,1	2.5/1,9	3.0/2,2
Voltage	60 Hz	115/230-1	208-230/460-3	230-1	208-230/460-3
	50 Hz	-	190-220/380-415-3	220-240-1	190-220/380-415-3
Amps	60 Hz	25/12.5	6.6-6.1/3.05	16.3	13-12/6
	50 Hz	-	5.0-4.4/2.5-2.6	14.7-13.5	14.4-13.4/7.2-6.8
Starting Amps	60 Hz	78 @ 230V	48 @ 230V	64 @ 230V	125 @ 230V
	50 Hz	-	Consult Factory	Consult Factory	Consult Factory
Insulation Class		F	F	F	F
Recommended NEMA Starter Size		1/0	0/0	1	1/0
Net Weight (lbs/kg)		77/35	75/34	129/59	112/51

MODEL NUMBER		R6P155Q-50	R6P355R-50	R7100R-50
Motor Enclosure		XPFC	XPFC	XPFC
HP/kW	60 Hz	5.5/4,1	6.0/4,5	10/7,5
	50 Hz	4.0/3,0	4.5/3,4	8.0/6,0
Voltage	60 Hz	230-1	208-230/460-3	208-230/460-3
	50 Hz	220-240-1	190-220/380-415-3	190-220/380-415-3
Amps	60 Hz	29.9	20-18/9	26.5-24/12
	50 Hz	20.8-19.1	14.9-11/7.45-5.8	23.2-21.0/11.6-10.9
Starting Amps	60 Hz	198.4 @ 230V	59 @ 460V	105 @ 460V
	50 Hz	189 @ 240V	Consult Factory	Consult Factory
Insulation Class		F	F	F
Recommended NEMA Starter Size		0/2	1/0	2/1
Net Weight (lbs/kg)		243/110	233/105	297/134



R3105N-50

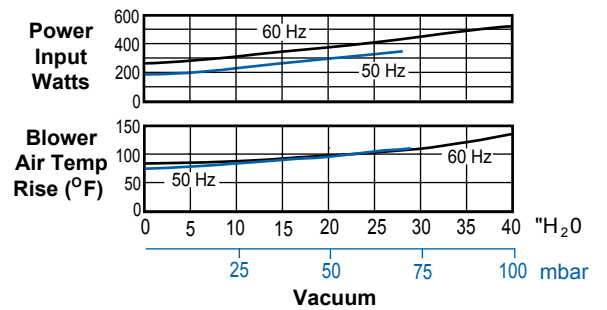
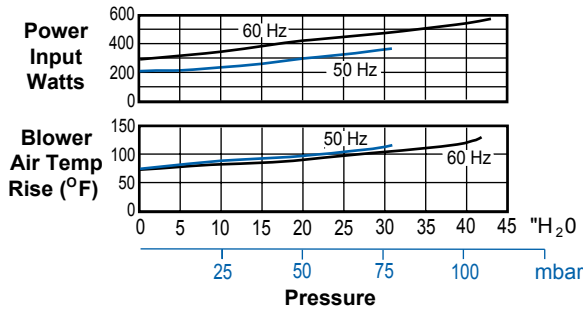
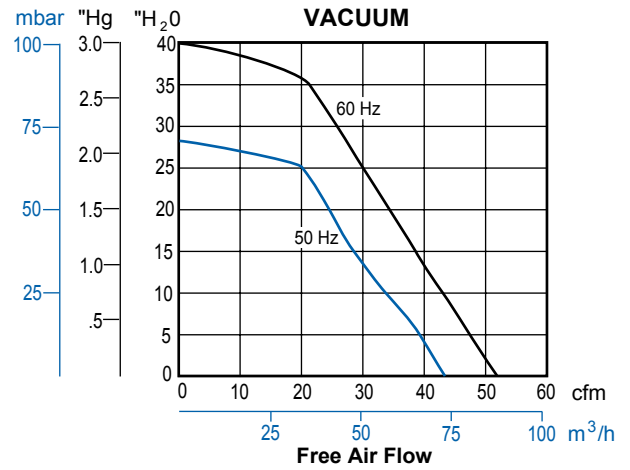
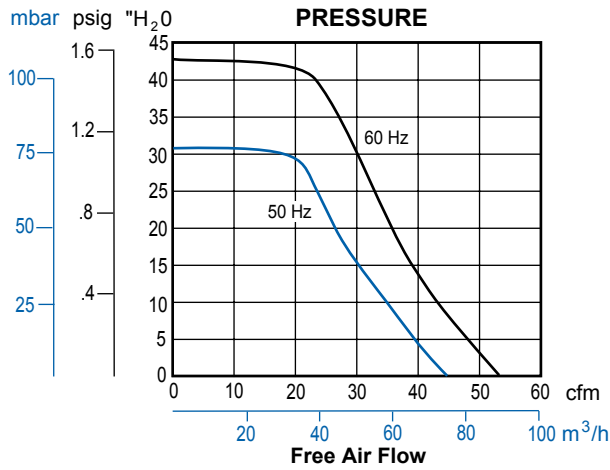

R4110N-50/R4310P-50

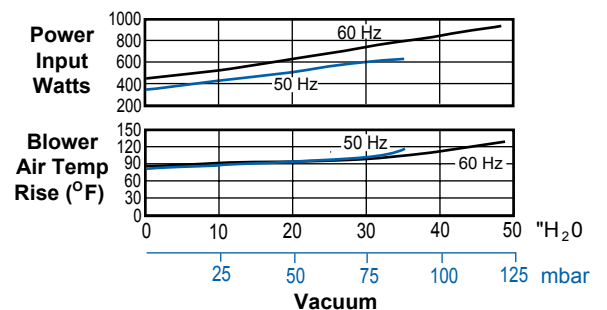
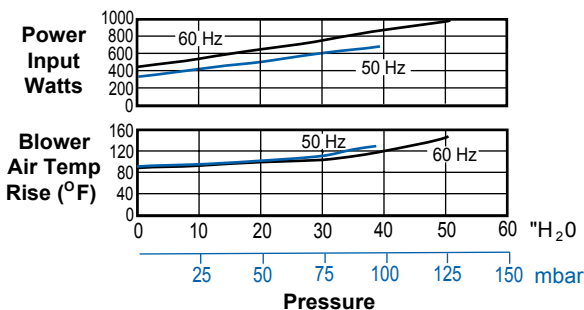
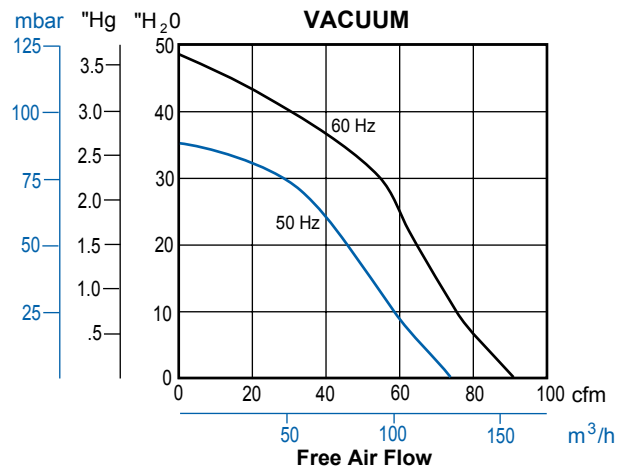
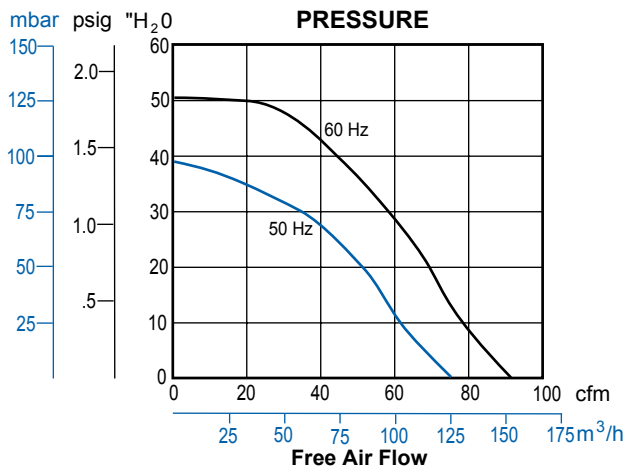



R4P115N-50

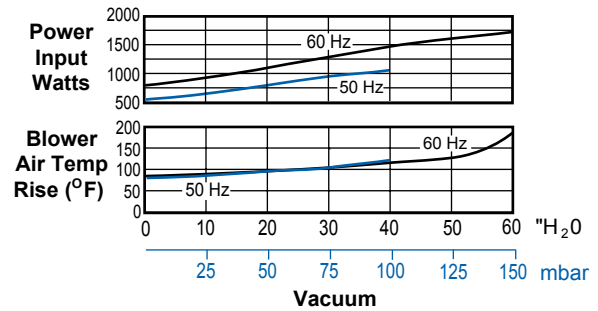
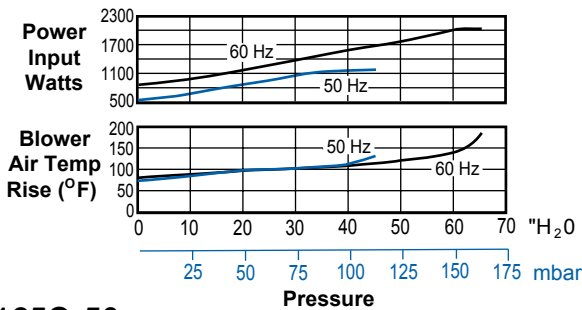
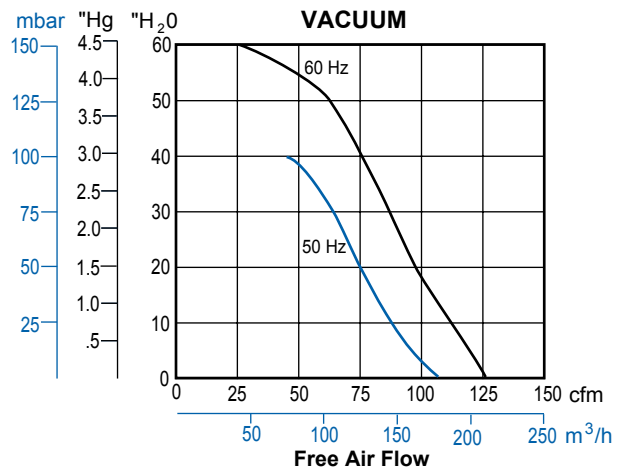
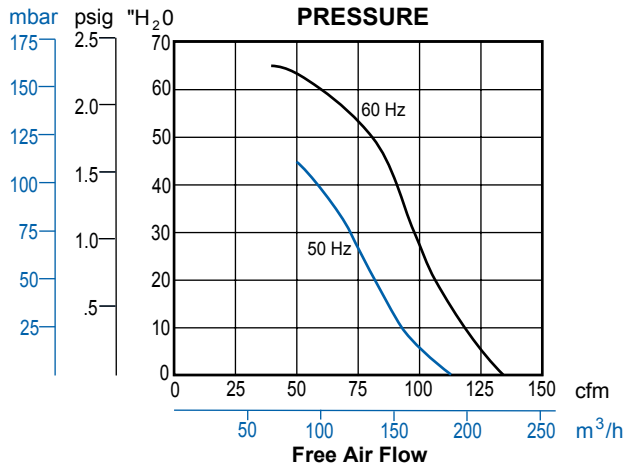

R5125Q-50

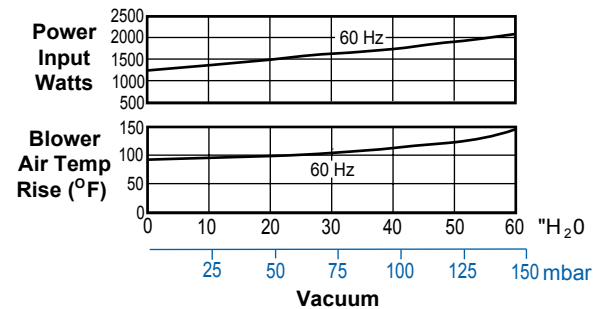
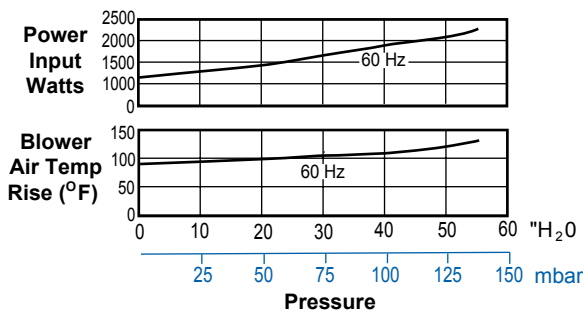
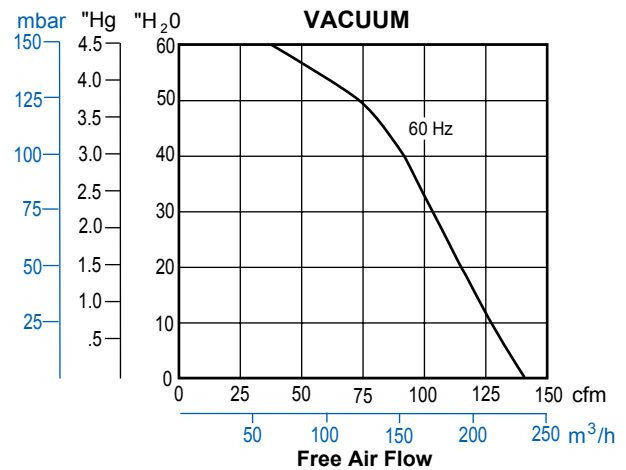
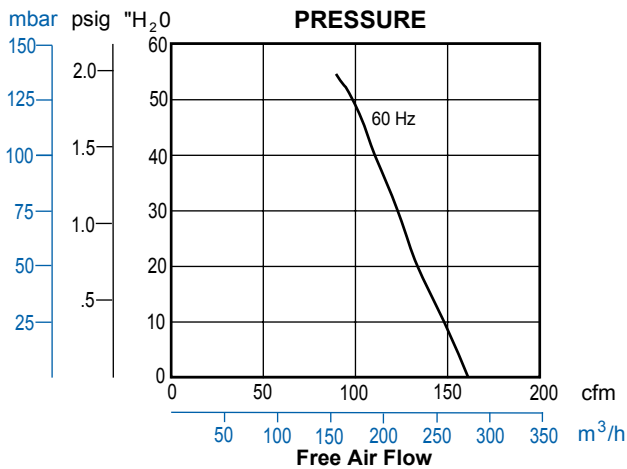



R5325R-50

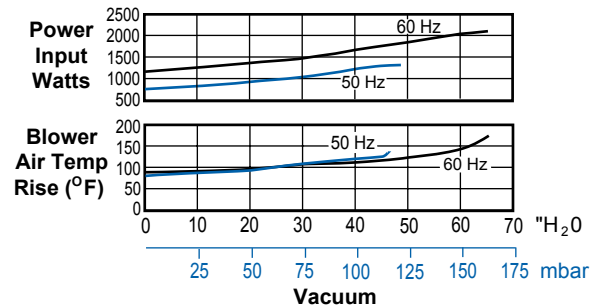
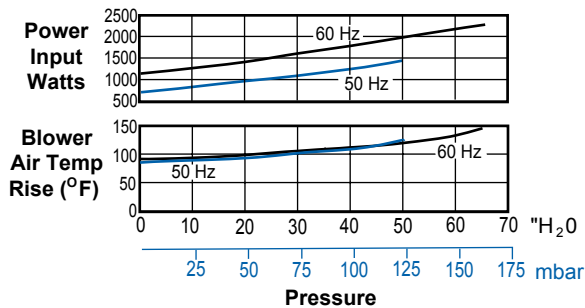
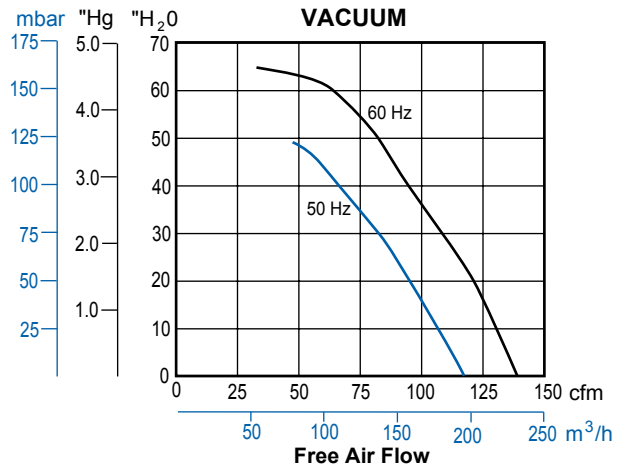
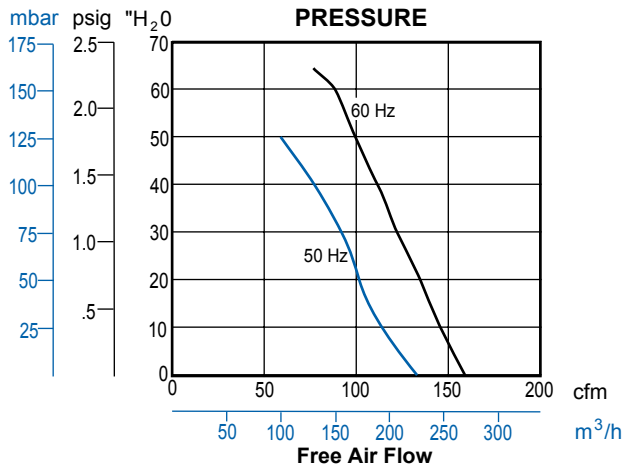

R6130Q-50

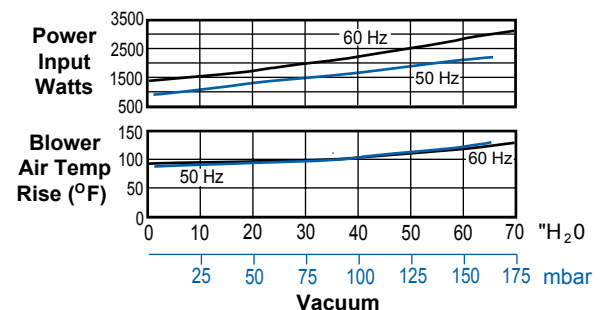
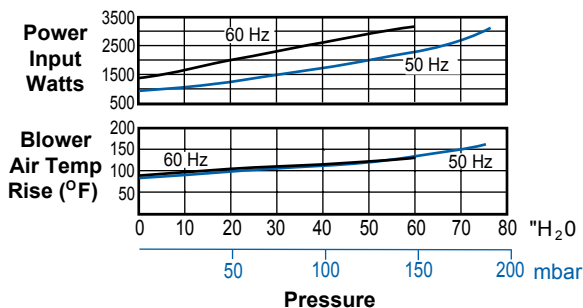
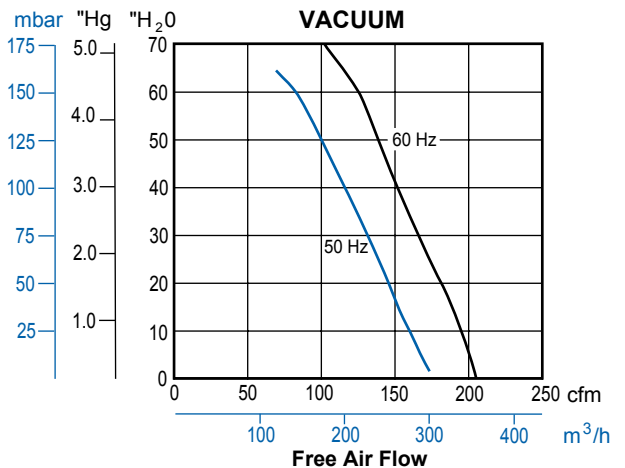
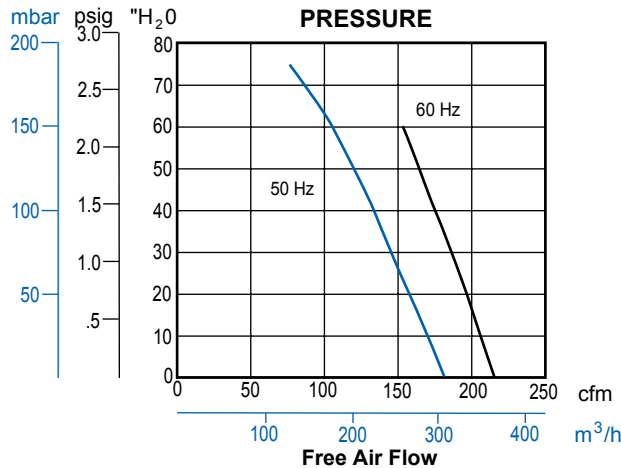



R6340R-50

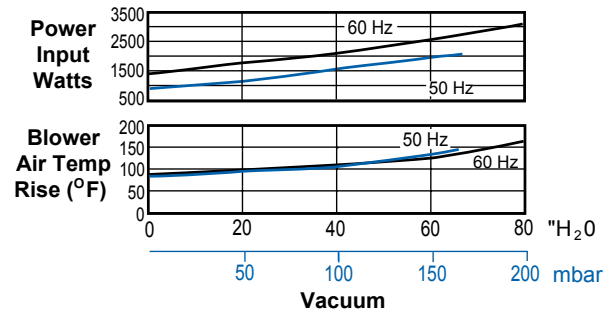
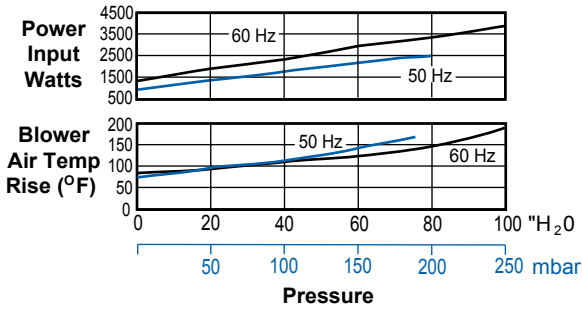
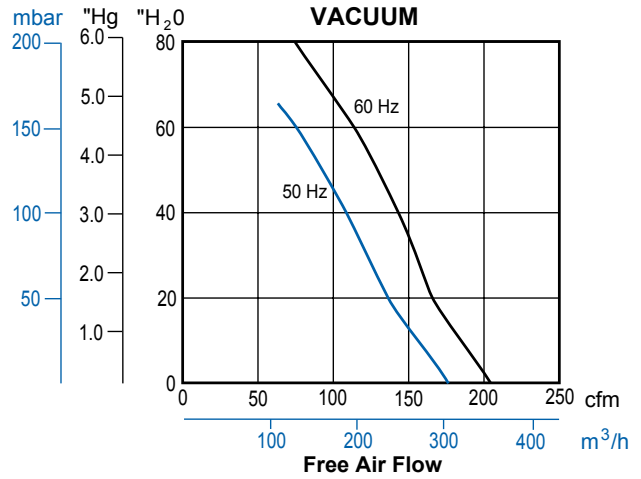
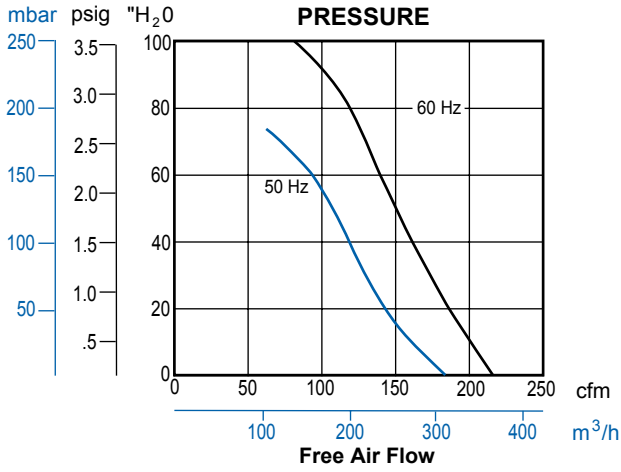

R6P155Q-50

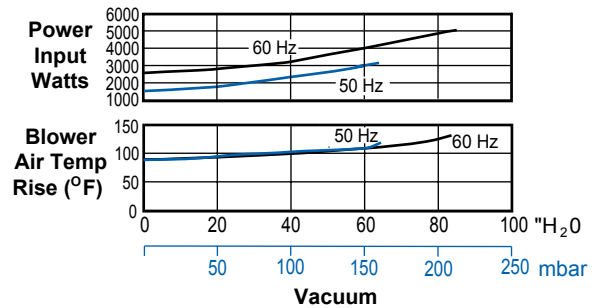
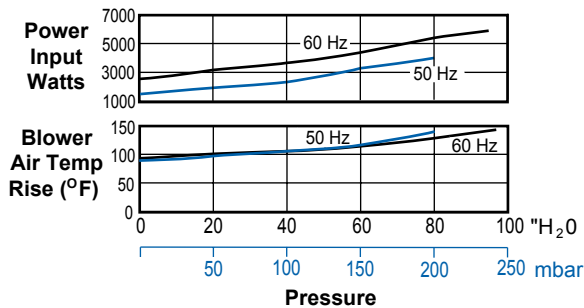
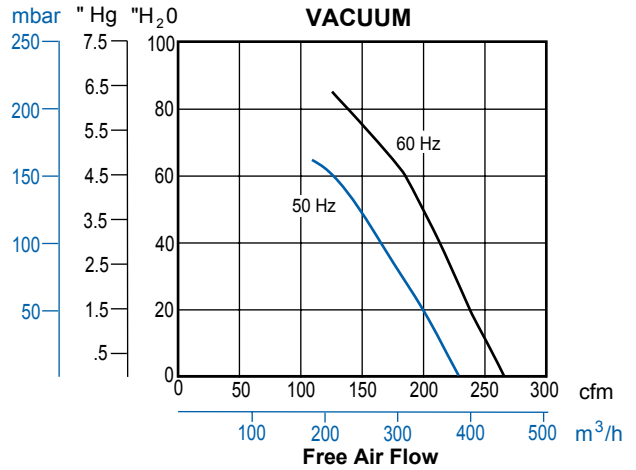
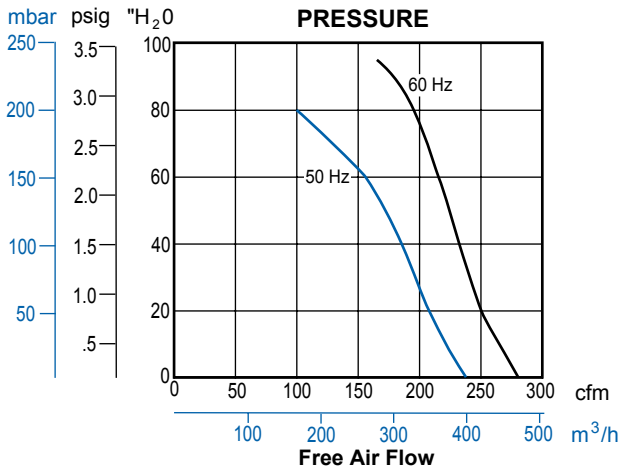



R6P355R-50

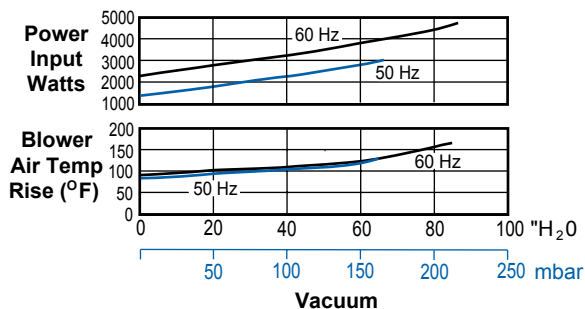
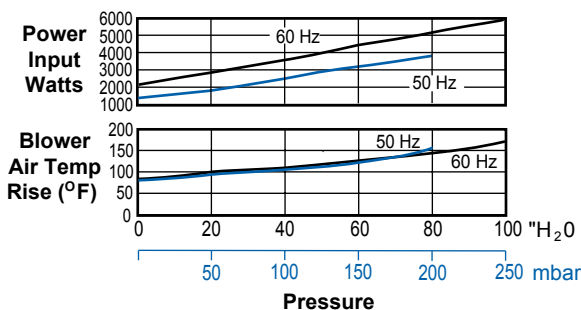
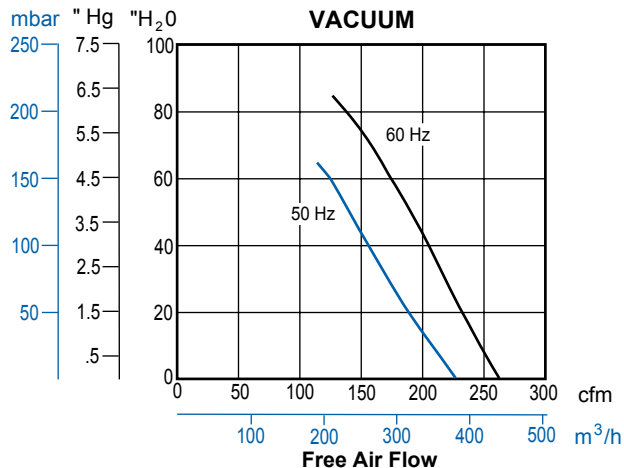
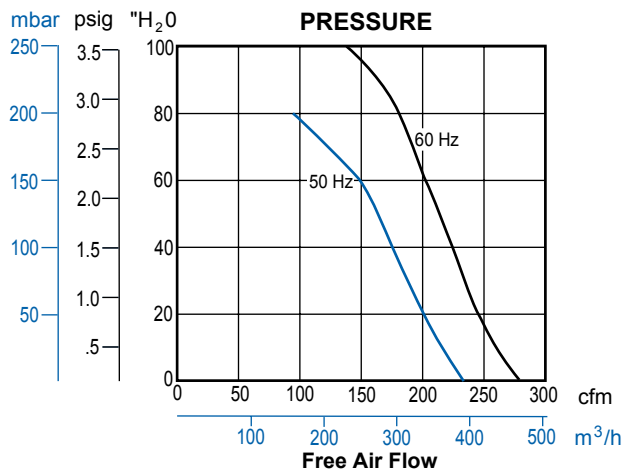

R7100R-50

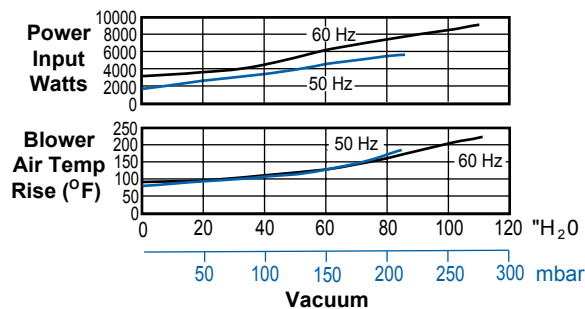
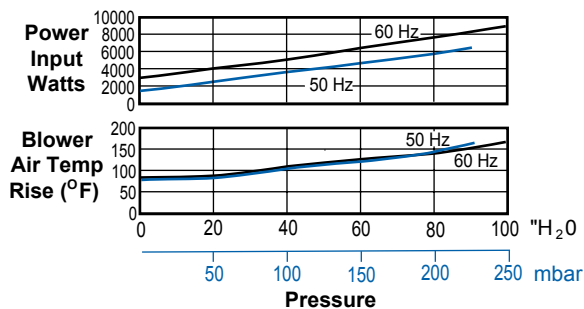
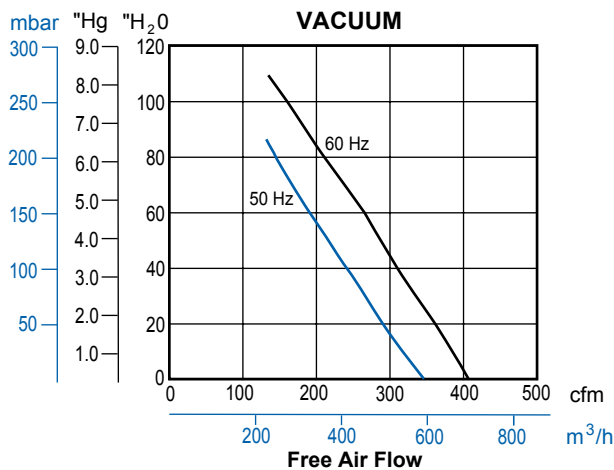
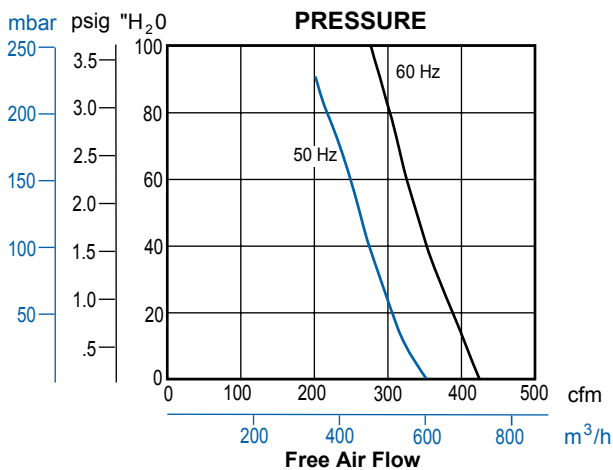



Product Specifications

MODEL NUMBER	SDR4	SDR5	SDR6	SDR6P
Maximum RPM	5500	5500	5500	4500
HP/kW required at maximum RPM and Vacuum	3/2,2	8/6	11.5/8,6	10.6/7,9
HP/kW required at maximum RPM and Pressure	4/3	10/7,5	15/11,1	15/11,1
Net Weight (lbs/kg)	27/12	37/17	70/32	111/50

SDR4

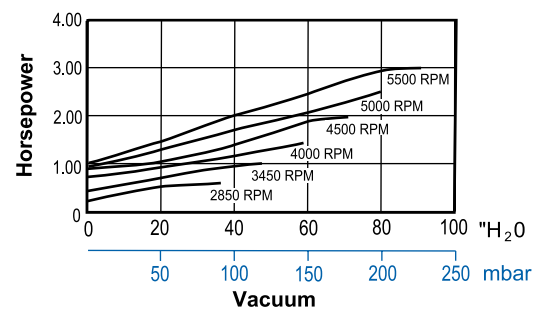
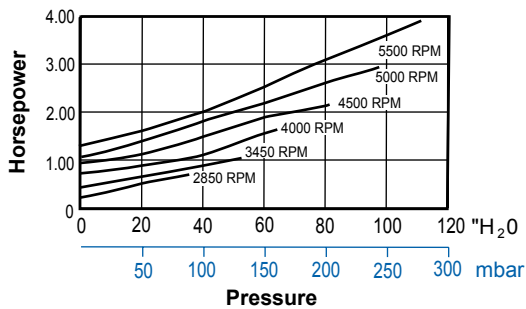
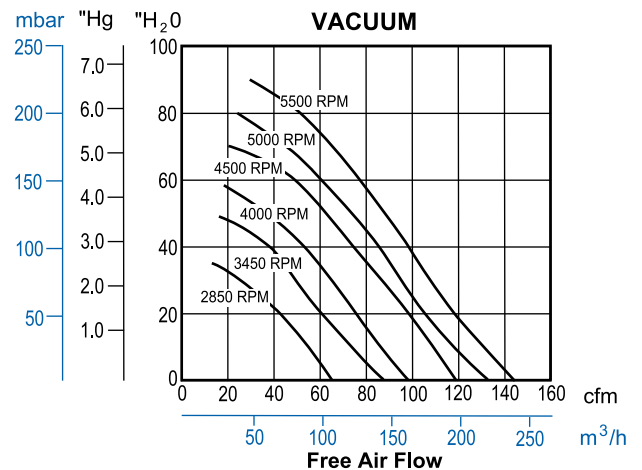
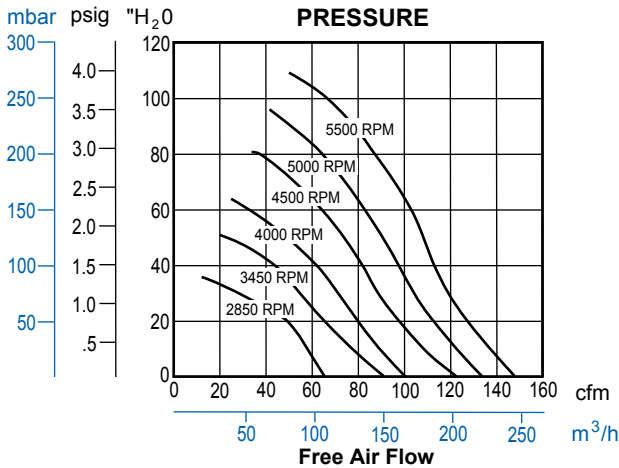



SDR5

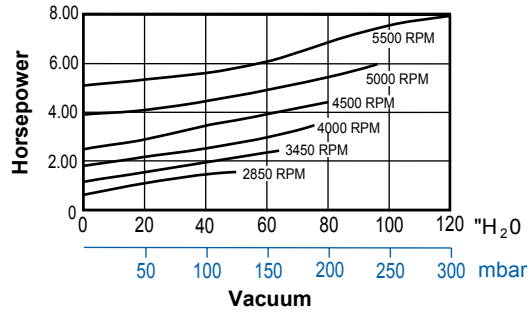
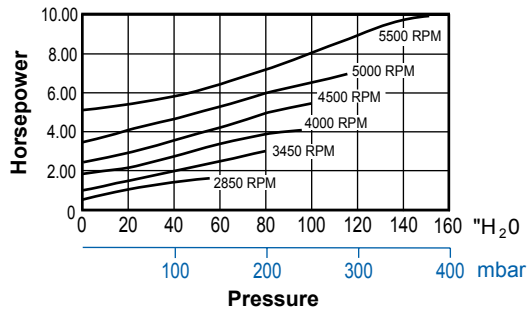
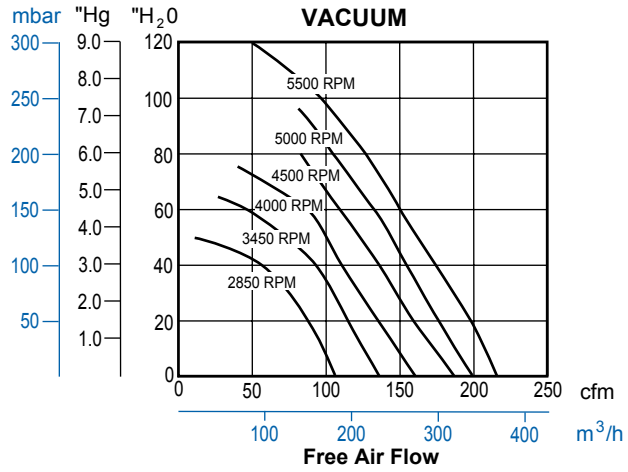
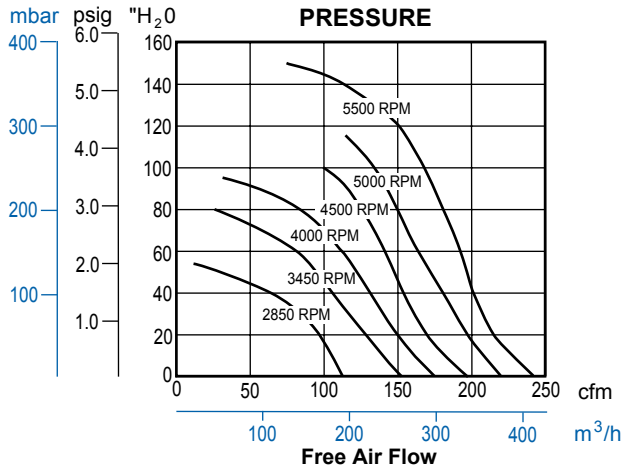

SDR6

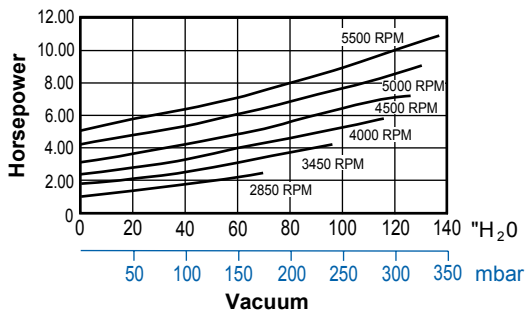
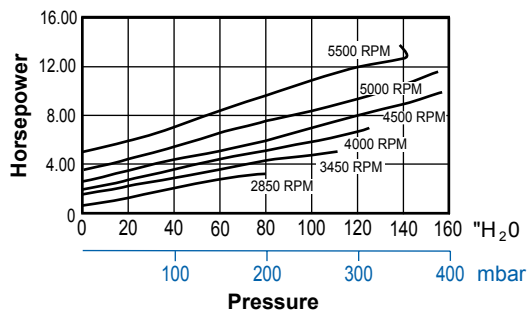
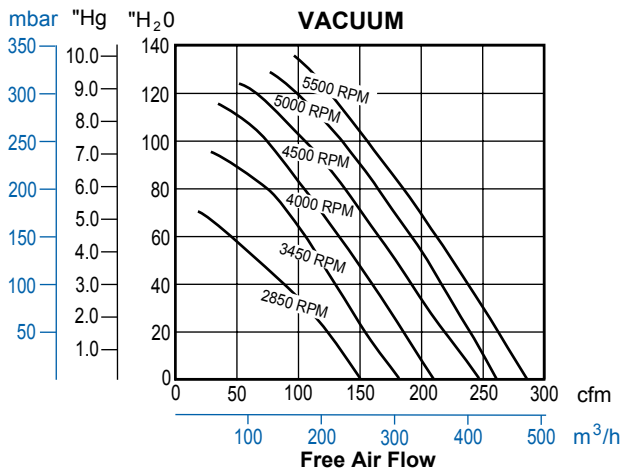
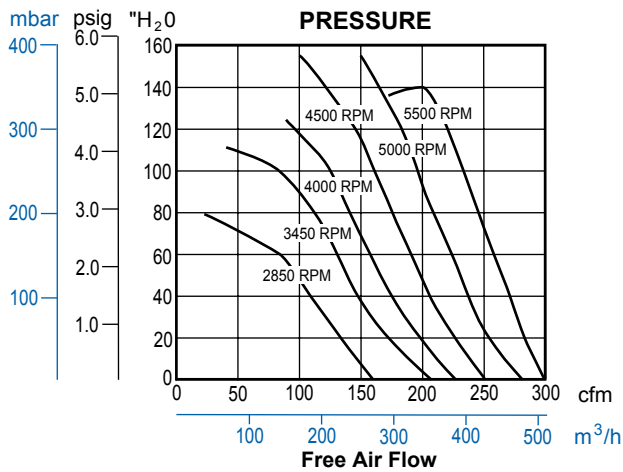



SDR6P

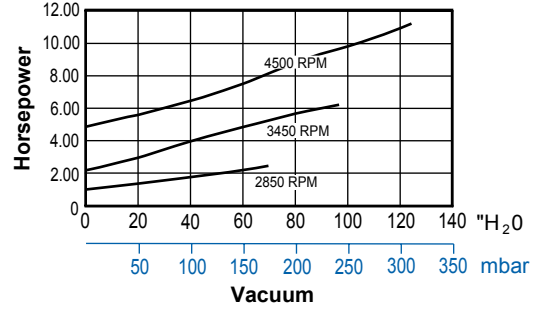
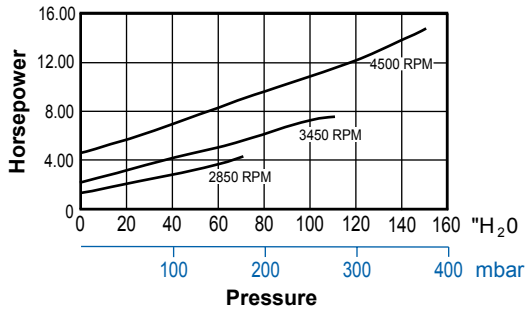
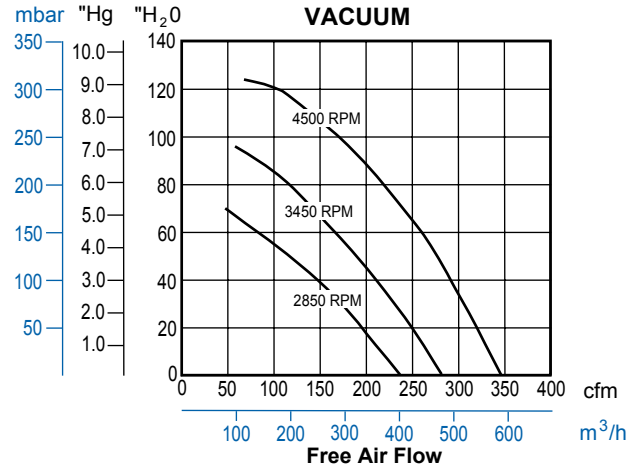
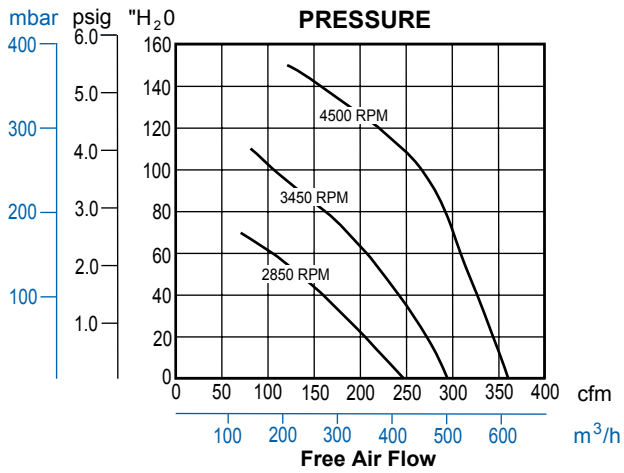



Regenair® Liquid Separator

The separator removes liquids from the gas stream in a soil vapor extraction process, to help protect both blower and vapor treatment system from corrosion and mineral deposit buildup. The separator is located between the extraction wells and the blower. An inline filter is installed between separator and blower.



Cut away to show ball float. Above model shows optional explosion proof float switch AJ213

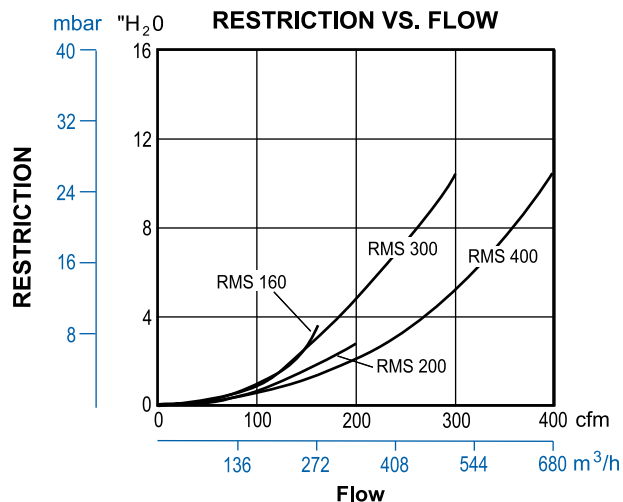

Specifications

Practical Design Engineered to remove and contain moisture ranging from a fine mist to slugs of water from blower inlet air streams, Gast separators incorporate a cyclonic action which results in a very high degree of efficiency.

A floating ball valve which closes when the liquid level becomes too high prevents collected liquid from overflowing back into the air stream. When the float valve closes an integral vacuum relief valve opens, admitting air to cool the blower and prevent overheating.

Rugged Construction Gast separator drums are made from ribbed heavy gauge cold-rolled steel, with heavy steel inlet, drain and float switch ports welded to the drum wall. Drum interiors are epoxy coated to resist abrasion, corrosion and chemicals, while the drum exterior is coated with durable urethane. For ease of connection, the outlet port of female pipe threaded. The heavy-duty 304 stainless steel ball float resists chemicals. Maximum rated vacuum is 22" Hg (299 "H₂O).

Included is a pilot operated precision relief valve capable of functioning over a wide duty range. This vacuum relief valve is designed and built to proven reliability and durability standards. Moving parts are nickelplated for corrosion resistance and smooth operation. Explosion proof AJ213 float switch is optional; single pole double throw, electrical rating 5 amp @ 125/250 VAC, 1" NPT mounting.

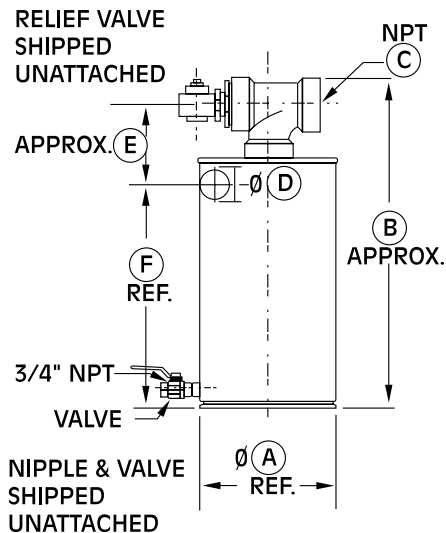

Part No.	Liq. Cap.(gal.)	A(dia.)	Dim. B	C(NPT)	D(dia.)	Dim. E	Dim. F	Used On
RMS160	10	14.8"	37.5"	2"	2"	7.5"	26.6"	R3, R4, R5
RMS200	19	19.7"	35"	2"	2"	7.5"	26.6"	R4, R4H, R4P, R5
RMS300	19	19.7"	35"	2.5"	2.5"	7.5"	26.6"	R4H, R4M, R5, R6, R6P, R6PS, R7H
RMS400	40	24"	44"	3"	3"	9.7"	29"	R6PP, R4M, R6, R6P, R7, R7S, R7P, R7H, R9, R9S

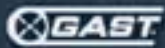

Mufflers

Designed to reduce noise by 5-8 dBa and remove high frequency sound associated with all blowers .

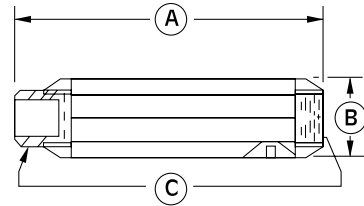

Part No.	Dim. A	Dim. B	Dim. C	Used On
AJ121B	7.46"	2.38"	1" NPT	R1, R2
AJ121C	7.94"	2.62"	1 1/4" NPT	R3
AJ121D	12.75"	3.25"	1 1/2" NPT	R4, R5, R4P, R4H, R7
AJ121F	17.05"	3.63"	2" NPT	R4H, R6, R6P, R6PP, R6PS
AJ121G	17.44"	4.25"	2 1/2" NPT	R7, R7P, R7S,
AJ121H	20.25"	4.75"	3" NPT	R6PP (Exhaust), R9, R9P, R9S
AJ121M	33.50"	6.00"	4" NPT	R7P (Exhaust)

Pressure-Vacuum Gauge

To monitor the system performance so maximum duties are not exceeded. Using two gauges (one on each side of the filter) is a great way to know when the filter needs servicing.



Part No.	Used On
AJ497 Vacuum gauge	0-60" H ₂ O, 1/4" NPT connection R1, R2, R3, R4 R4H, R4P, R5, R7, R7P, R7S, R9, R9P, R9S
AE134 Vacuum gauge	0-160" H ₂ O, 1/4" NPT connection R4P, R6PP, R6PS, R6P, R4M, R6, R7, R7S, R7P, R9, R9P, R9S
AE134F Vacuum gauge	0-15" Hg, 1/4" NPT connection R4H,
AE133 Pressure gauge	0-160" H ₂ O, 1/4" NPT connection R6PP, R6P, R5, R4P, R6, R7P, R9, R9P
AE133A Pressure gauge	0-200" H ₂ O, 1/4" NPT connection R6PS, R7, R7S
AE133F Pressure gauge	0-15 psi, 1/4" NPT connection R4H, R9S
AJ496 Pressure gauge	0-60" H ₂ O, 1/4" NPT connection R1, R2, R3, R4

Check Valve

Designed to prevent back-wash of fluids that would enter the blower. Also prevents air back-streaming if needed. Can be mounted with discharge either vertical or horizontal. Valve will open with 3" of water pressure.

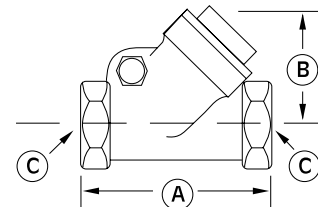

Part No.	Dim. A	Dim. B	Dia. C
AH326B	3.57"	2.32"	1" NPT
AH326C	4.19"	2.69"	1 1/4" NPT
AH326D	4.50"	2.94"	1 1/2" NPT
AH326F	5.25"	3.82"	2" NPT

Relief Valve

By setting a relief valve at a given pressure/vacuum you can ensure excessive duties will not harm the blower or products in your application.

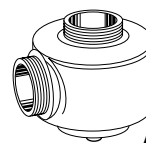

AG258 Series

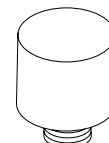

PV Series

Part No.	Used On
AG258 Relief valve	1-1/2" NPT adjustable 30-200" H ₂ O, vac. or press., 200 CFM max R4, R4H, R4P, R5, R6, R6P, R6PS, R7
AG258F Relief valve	2-1/2" NPT adjustable 25-200" H ₂ O, vacuum or pressure, 570 CFM R6PP, R7P, R7S, R9, R9P, R9S
PV102 Relief valve	For pressure, pre-set for 10.2 psi, 1-1/4" NPT connection (60Hz) R4H



Filters

Inlet filters (for pressure)

Part No.	Dim. A	Dim. B	Dim. C	Filter Replacement	Used On
AJ126B	6.00"	4.62"	1" MPT	AJ134B (10 micron)	R1, R2
AJ126C	6.00"	7.12"	1 1/4" MPT	AJ134C (10 micron)	R3
AJ126D	7.70"	7.25"	1 1/2" MPT	AJ134E (10 micron)	R4, R4H, R4P, R5
AJ126F	10.63"	4.81"	2" MPT	AG340 (10 micron)	R6, R6P, R6PS, R6PP, R9
AJ126G	10.00"	13.12"	2 1/2" MPT	AJ135A (10 micron)	R7, R7P,
AJ126L	10.00"	14.62"	4" MPT	AJ135C (10 micron)	Consult factory
AJ126M	16.00"	14.62"	5" MPT	AJ135H (10 micron)	Consult factory

MPT = Male Pipe Thread FPT = Female Pipe Thread All are heavy-duty for high amounts of particulates. Inlet filters for REGENAIR® blowers are drip-proof when mounted as shown.

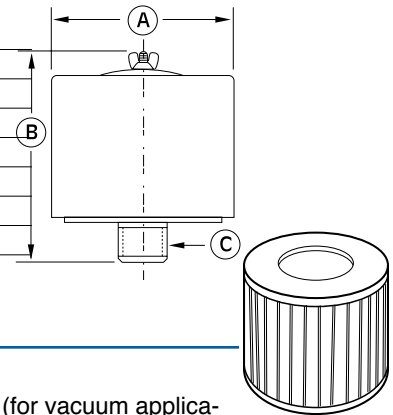

Filters

In locations where there are high amounts of dust, powder or dirt suspended in the air, inline filters (for vacuum applications) and inlet filters (pressure applications), should be used. Keeping particulates from entering the blower will ensure smooth operation and trouble free service life.

Inline filters (for vacuum)

AV series

Part No.	Dim. A	Dim. B	Dim. C	Dim. D	Used On
AV460	8 1/4"	8 7/8"	1" FPT	1" FPT	R1, R2
AV460C	8 1/4"	8 7/8"	1 1/4" FPT	1 1/4" FPT	R3

Replacement elements for AV460 and AV460C:

AV463A - Cloth bag, 50 micron, sold in 3 pack (letter F on diagram).

AV469A - Paper filter, 5-10 micron, sold in 12 pack (letter E on diagram).

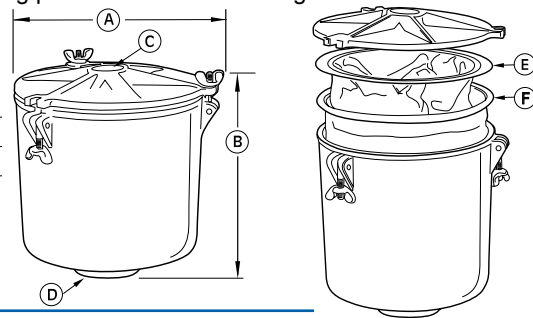

AJ series

Part No.	Dim. A	Dim. B	Dim. C	Dim. D	Dim. E	Filter Replacement	Used On
AJ151A	5.88"	4.50"	2.75"	1" FPT	1" FPT	AJ135D (10 micron)	R1
AJ151B	7.38"	6.81"	4.62"	1" FPT	1" FPT	AJ135E (10 micron)	R2
AJ151C	7.38"	6.81"	4.62"	1 1/4" FPT	1 1/4" FPT	AJ135E (10 micron)	R3
AJ151D	7.38"	6.81"	4.62"	1 1/2" FPT	1 1/2" FPT	AJ135E (10 micron)	R4, R4P
AJ151E	8.75"	10.25"	5.00"	2" FPT	2" FPT	AJ135F (10 micron)	R4H, R4P, R5
AJ151G	8.75"	10.50"	5.50"	2 1/2" FPT	2 1/2" FPT	AJ135G (10 micron)	R6, R6P,
AJ151H	14.00"	27.13"	18.50"	3" MPT	3" MPT	AJ135C (10 micron)	R6PP, R6PS, R7
AJ151M	18.50"	28.13"	19.50"	5" MPT	5" MPT	AJ135H (10 micron)	R7P, R7S, R9, R9P, I

MPT = Male Pipe Thread FPT = Female Pipe Thread All are heavy-duty for high amounts of particulates.

Inline filters for REGENAIR® blowers are drip-proof when mounted as shown.

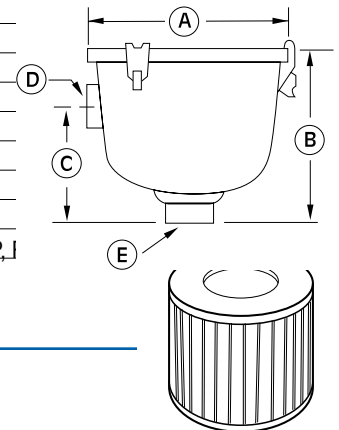

Regenair® Filter Restrictions with Clean Element

Inlet Filters

Blower Size	Filter Number	Restriction in Inches of H ₂ O at CFM Flow Indicated
R1	AJ126B	2.2" @ 27 CFM
R2	AJ126B	4.5" @ 40 CFM
R3	AJ126C	2.5" @ 50 CFM
R4H	AJ126D	8" @ 120 CFM
R4	AJ126D	4" @ 85 CFM
R4P	AJ126D	8" @ 120 CFM
R5	AJ126D	11" @ 146 CFM
R6	AJ126F	7" @ 200 CFM
R6P/R6PS	AJ126F	11" @ 265 CFM
R6PP	(2) AJ126F	10" @ 240 CFM
R7/R7S	AJ126G	12" @ 400 CFM
R7P	(2) AJ126G	12" @ 400 CFM
R9S	AJ126M	Consult factory
R9P	AJ126M	Consult factory

Inline Filters

Blower Size	Filter Number	Restriction in Inches of H ₂ O at CFM Flow Indicated
R1	AJ151A	1" @ 25 CFM
	AV460	2" @ 25 CFM
R2	AJ151B	2" @ 40 CFM
	AV460	5" @ 40 CFM
R3	AJ151C	2" @ 50 CFM
	AV460C	3" @ 50 CFM
R4	AJ151D	3" @ 100 CFM
R4P	AJ151E	3" @ 100 CFM
R4H	AJ151E	3" @ 120 CFM
R5	AJ151E	4" @ 160 CFM
R6	AJ151G	2" @ 200 CFM
R6P/R6PS	AJ151G	3" @ 300 CFM
6PP	AJ151H	8" @ 400 CFM
R9S	AJ151 M	Consult factory
R9P	AJ151 M	Consult factory



Standard Conversions

Multiply	By	To Get
Atmospheres	29.92	Inches of Mercury
Atmospheres	14.70	Psi
Atomspheres	76.0	Cms of Mercury
Bars	0.9869	Atmospheres
Bars	14.50	Psi
British Thermal Units	3.927×10^{-4}	Horsepower-Hours
British Thermal Units	2.928×10^{-4}	Kilowatt-Hours
Centimeters of Mercury	0.1934	Psi
Cubic Feet	7.481	Gallons
Cubic Feet	28.32	Liters
Cubic Feet/Minute	1.6992	Cubic Meters/Hour
Cubic Meters/Hour	.5886	Cubic Feet/Minute
Cubic Meters	35.31	Cubic Feet
Cubic Meters	61,023	Cubic Inches
Cubic Meters	1.308	Cubic Yards
Horsepower	42.44	British Thermal Units/Min.
Horsepower	745.7	Watts
Horsepower	.746	Kilowatts
Horsepower-Hours	2547	British Thermal Units
Inches	2.540	Centimeters
Inches	25.40	Millimeters
Inches of Mercury	0.03342	Atomspheres
Inches of Mercury	13.60	Inches of Water
Inches of Mercury	0.4912	Psi
Inches of Water	0.07355	Inches of Mercury
Inches of Water	25.40	Kgs/Sq. Meter
Inches of Water	0.03613	Psi
Inches of Water	1.868	Mm of Mercury
Inches of Water	2.491	mbar
Kilograms/Sq. cm	14.22	Psi
Kilopascals (kpa)	0.145	Psi
Kilowatts	1.341	Horsepower
Kilowatts	56.92	British Thermal Units/Min.
Kilowatt-Hours	3415	British Thermal Units
Liters	61.02	Cubic Inches
Liters	0.03531	Cubic Feet
Millibar	.0145	Psi
Millibar	.402	Inches of Water
Mms. of Mercury	0.0394	Inches of Mercury
Mms. of Mercury	0.01934	Psi
Psi	0.06804	Atmospheres
Psi	27.7	Inches of Water
Psi	2.036	Inches of Mercury
Psi	.07031	Kgs/Sq. Centimeter
Psi	6.895	Kilopascals (kpa)
Psi	68.95	mbar
Psi	.069	bar
Pounds of Water	27.68	Cubic Inches
Pounds of Water		
Evaporated at 212° F	970.3	British Thermal Units
Temp. (Degs.C.) + 273	1	Abs. Temp. (Degs.C.)
Temp. (Degs.C.) + 17.8	1.8	Temp. (Degs. Fahr.)
Temp. (Degs. F.) + 460	1	Abs. Temp. (Degs F.)
Temp. (Degs. F.) - 32	5/9	Temp. (Degs. Cent.)
Watts	0.05692	British Thermal Units/Min.
Watts	1.341×10^{-3}	Horsepower
Watts	10^{-3}	Kilowatts
Watts-Hour	3.415	British Thermal Units
Watts-Hour	1.341×10^{-3}	Horsepower/Hours
Watts-Hour	10^{-3}	Kilowatt-Hours

VACUUM-PRESSURE EQUIVALENCE TABLE

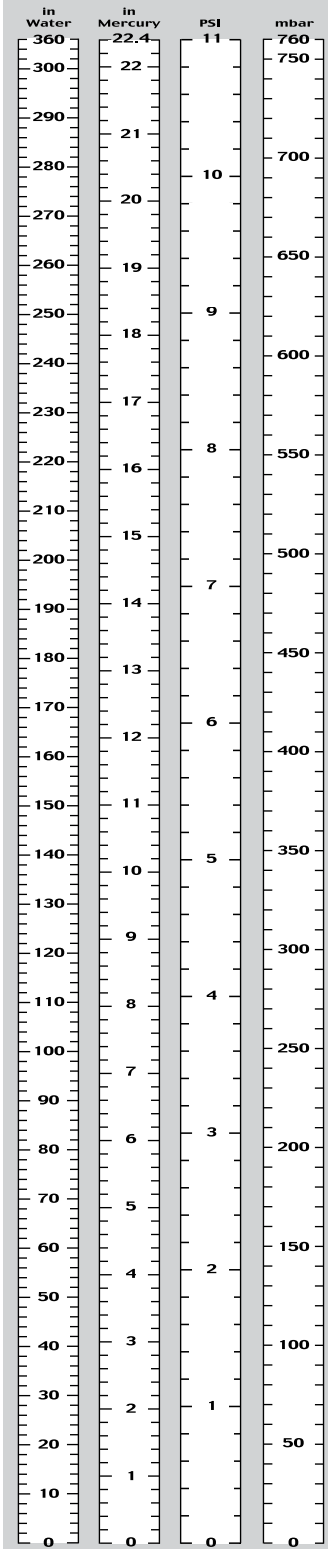



IP Codes (Ingress Protection)

IEC 60529 outlines an international classification system for the sealing effectiveness of enclosures of electrical equipment against the intrusion into the equipment of foreign bodies (i.e., tools, dust, fingers) and moisture. This classification system utilizes the letters "IP" ("Ingress Protection") followed by two digits. (An "X" is used for one of the digits if there is only one class of protection; i.e., IP X 4 which addresses moisture resistance only.)

Degrees of Protection - First Digit

The first digit of the IP code indicates the degree that persons are protected against contact with moving parts (other than smooth rotating shafts, etc.) and the degree that equipment is protected against solid foreign bodies intruding into an enclosure.

- 0 No special protection
- 1 Protection from a large part of the body such as a hand (but no protection from deliberate access); from solid objects greater than 50 mm in diameter
- 2 Protection against fingers or other objects not greater than 80mm in length and 12 mm in diameter

- 3 Protection from entry by tools, wires, etc., with a diameter or thickness greater than 2.5 mm
- 4 Protection from entry by solid objects with a diameter or thickness greater than 1.0 mm
- 5 Protection from the amount of dust that would interfere with the operation of the equipment
- 6 Dust-tight

Degrees of Protection - Second Digit

Second digit indicates the degree of protection of the equipment inside the enclosure against the harmful entry of various forms of moisture (e.g. dripping, spraying, submersion, etc.).

- 0 No special protection
- 1 Protection from dripping water
- 2 Protection from vertically dripping water
- 3 Protection from sprayed water
- 4 Protection from splashed water
- 5 Protection from water projected from a nozzle
- 6 Protection against heavy seas, or powerful jets of water
- 7 Protection against immersion
- 8 Protection against complete, continuous submersion in water

Air Flow Through An Orifice (in CFM)

- Downstream pressure = 14.7 psia (standard atmospheric pressure)
- Air Temperature = 70°F (21°C)
- Cd (discharge coefficient) = 0.65 (for sharp edge orifice — See drawing)

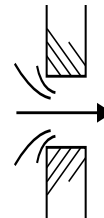

Up Stream Pressure

Orifice Diameters (in Inches)

in. H ₂ O	1/32	1/16	1/8	3/16	1/4	5/16	3/8	7/16	1/2	3/4	1	1 1/4	1 1/2	1 3/4	2	2 1/4	2 1/2	2 3/4	3
1.00	0.014	0.054	0.217	0.489	0.869	1.36	1.96	2.66	3.48	7.82	13.9	21.7	31.3	42.6	55.6	70.4	86.9	105	125
2.00	0.019	0.077	0.307	0.691	1.23	1.92	2.76	3.76	4.92	11.1	19.7	30.7	44.2	60.2	78.6	99.5	123	149	177
3.00	0.024	0.094	0.376	0.846	1.50	2.35	3.39	4.61	6.02	13.5	24.1	37.6	54.2	73.7	96.3	122	150	182	217
4.00	0.027	0.109	0.434	0.977	1.74	2.71	3.91	5.32	6.95	15.6	27.8	43.4	62.6	85.1	111	141	174	210	250
5.00	0.030	0.121	0.486	1.09	1.94	3.04	4.37	5.95	7.77	17.5	31.1	48.6	69.9	95.2	124	157	194	235	280
10.00	0.043	0.172	0.686	1.54	2.75	4.29	6.18	8.41	11.0	24.7	43.9	68.6	98.9	135	176	222	275	332	395
15.00	0.053	0.210	0.840	1.89	3.36	5.25	7.56	10.3	13.4	30.3	53.8	84.0	121	165	215	272	336	407	484
20.00	0.061	0.242	0.970	2.18	3.88	6.06	8.73	11.9	15.5	34.9	62.1	97.0	140	190	248	314	388	469	559
25.00	0.068	0.271	1.08	2.44	4.34	6.77	9.76	13.3	17.3	39.0	69.4	108	156	212	277	351	434	525	624
30.00	0.074	0.297	1.19	2.67	4.75	7.42	10.7	14.5	19.0	42.7	76.0	119	171	233	304	385	475	574	684
35.00	0.080	0.320	1.28	2.88	5.13	8.01	11.5	15.7	20.5	46.1	82.0	128	185	251	328	415	513	620	738
40.00	0.086	0.342	1.37	3.08	5.48	8.56	12.3	16.8	21.9	49.3	87.6	137	197	268	351	444	548	663	789
45.00	0.091	0.363	1.45	3.27	5.81	9.07	13.1	17.8	23.2	52.3	92.9	145	209	285	372	470	581	703	836
50.00	0.096	0.382	1.53	3.44	6.12	9.56	13.8	18.7	24.5	55.1	97.9	153	220	300	392	496	612	740	881
55.00	0.100	0.401	1.60	3.61	6.41	10.0	14.4	19.6	25.7	57.7	103	160	231	314	411	520	641	776	924
60.00	0.105	0.419	1.67	3.77	6.70	10.5	15.1	20.5	26.8	60.3	107	167	241	328	429	542	670	810	964
65.00	0.109	0.435	1.74	3.92	6.97	10.9	15.7	21.3	27.9	62.7	111	174	251	341	446	564	697	843	1003
70.00	0.113	0.452	1.81	4.06	7.23	11.3	16.3	22.1	28.9	65.0	116	181	260	354	463	585	723	874	1041
75.00	0.117	0.467	1.87	4.21	7.48	11.7	16.8	22.9	29.9	67.3	120	187	269	366	479	606	748	905	1077
80.00	0.121	0.482	1.93	4.34	7.72	12.1	17.4	23.6	30.9	69.5	124	193	278	378	494	625	772	934	1112
85.00	0.124	0.497	1.99	4.47	7.95	12.4	17.9	24.4	31.8	71.6	127	199	286	390	509	644	795	962	1145
90.00	0.128	0.511	2.04	4.60	8.18	12.8	18.4	25.1	32.7	73.6	131	204	294	401	524	663	818	990	1178
95.00	0.131	0.525	2.10	4.73	8.40	13.1	18.9	25.7	33.6	75.6	134	210	302	412	538	680	840	1016	1210
100.00	0.135	0.538	2.15	4.85	8.61	13.5	19.4	26.4	34.5	77.5	138	215	310	422	551	698	861	1042	1241
105.00	0.138	0.551	2.21	4.96	8.82	13.8	19.9	27.0	35.3	79.4	141	221	318	432	565	715	882	1068	1271
110.00	0.141	0.564	2.26	5.08	9.03	14.1	20.3	27.6	36.1	81.2	144	226	325	442	578	731	903	1092	1300



Technical Information and Definitions

Definitions:

CFM—cubic feet of air per minute	d—density in pounds per cubic foot
SP—static pressure inches of water	1—known conditions
HP—horsepower	2—desired conditions
RPM—speed in revolutions per minute	

Standard Air—air at 68°F (absolute temperature 528°) and 29.92" Hg. (barometric pressure at sea level). The density of such air is 0.075 lbs./cu.ft. and the specific volume is 13.29 cu. ft./lb. The specific gravity is 1.0.

H₂O CFM vs SCFM

The difference between "Cubic Feet Per Minute" and "Standard Cubic Feet Per Minute" is simply one of air density. The word "Standard", in this unit of measure, refers to the air being at standard temperature and pressure. In this case it will have standard air density. Regenair blowers performance is stated in terms of CFM, the volume of air they move.

Fan Laws

The following fan laws apply for the range of air performance where induction motor-driven blowers operate, that is, under 100 inches of water static pressure or vacuum (where it may be assumed that air is incompressible). The fan laws may also be used if the pressure of both fan conditions is over 100 inches of water but the pressure change is less than 30%.

1. Effect Of A Speed Change

CFM is proportional to Speed (The volume changes in direct ratio to the speed)	$CFM_2 = CFM_1 \times (RPM_2/RPM_1)$
SP is proportional to Speed ² (The pressure changes as the square of the speed ratio)	$SP_2 = SP_1 \times (RPM_2/RPM_1)^2$
HP is proportional to Speed ³ (The horsepower changes as the cube of the speed ratio)	$HP_2 = HP_1 \times (RPM_2/RPM_1)^3$ (Also known as the 1-2-3 rule of blowers)

2. Altitude And Temperature Change The Density Of Air

CFM is constant	$CFM_2 = CFM_1$
SP is proportional to density	$SP_2 = SP_1 (d_2/d_1)$
HP is proportional to density	$HP_2 = HP_1 (d_2/d_1)$

Volume Changes In Direct Ratio To Speed

For example, a blower is operating at 3500 RPM and delivering 800 cfm. If the speed is reduced to 3000 RPM, what is the new volume?

Let:

V_1 —original volume	RPM_1 —original speed
V_2 —new volume	RPM_2 —new speed

$$V_2 = V_1 \times (RPM_2/RPM_1)^1 \qquad V_2 = 800 \times (3000/3500)^1 = 800 \times .857 = 686 \text{ CFM}$$

Pressure Changes As The Square Of The Speed Ratio

For example, a blower is operating at a speed of 3500 RPM and delivering air at 3 psi. If the speed is reduced to 3000 RPM, what is the new pressure?

Let:

P_1 —original pressure (3 psi)
P_2 —new pressure
RPM_1 —original speed
RPM_2 —new speed

$$P_2 = P_1 \times (RPM_2/RPM_1)^2 \qquad P_2 = 3 \times (3000/3500)^2 = 3 \times .735 = 2.21 \text{ psig} = 83 \text{ inches of water pressure}$$



Air Density Varies In Inverse Proportion To Absolute Temperature

For example, a blower is to handle 150°F air at 40 inches of water pressure. What pressure (standard air) blower is required?

Let:

P_1 –pressure hot air (40 inches of water)

P_2 –pressure standard air

AT_1 –absolute temperature hot air (150+460=610°)

AT_2 –absolute temperature standard air (68+460=528°)

$$P_2 = P_1 \times (AT_1/AT_2)$$

$$P_2 = 40 \times (610/528) = 40 \times 1.15 = 46 \text{ inches of water}$$

Temperature in Degrees of Fahrenheit	% Of Change In Air Density Compared to 70°
100	-5
90	-4
70	0
60	+2
50	+4
40	+6
30	+8
20	+10
10	+13

If a blower is capable of delivering 30 inches of water pressure with standard air, what pressure will it develop handling 150°F inlet air?

$$P_1 = P_2 \times (AT_2/AT_1)$$

$$P_1 = 30 \times (528/610) = 30 \times 0.866 = 26 \text{ inches of water pressure}$$

Relation Of Density To Inlet Volume

At high altitudes it is frequently specified that a specific blower must be capable of handling a given volume of “standard air”. For example, a blower is to operate at 5000 feet and is to handle 500 CFM of standard air. To determine the equivalent volume of air the blower must handle at the higher altitude:

Let:

V_1 –volume of standard air (500 CFM)

Hg_1 –barometric pressure sea level (29.92)

$$V_2 = V_1 \times (Hg_1/Hg_2)$$

feet altitude

V_2 –volume of thinner air

Hg_2 –barometric pressure at altitude (24.89 for 5000 feet)

$$V_2 = 500 \times (29.92/24.89) = 601 \text{ CFM of air at 5000}$$

Pressure Varies In Direct Proportion To Density

For example, a blower operating at 80 inches of water with standard air is to be used to handle air having a specific gravity of 0.8. What pressure does the blower create when handling the air?

Let:

P_a – air pressure

SG – specific gravity of gas

$$P_g = P_a \times SG$$

P_g – gas pressure

$$P_g = 80 \times 0.8 = 64 \text{ inches of water}$$

Horsepower Changes As The Cube Of The Speed Ratio

For example, a blower is operating at a speed of 3500 RPM and requiring 5 horsepower. If the speed is reduced to 3000 RPM, what is the new required horsepower?

Let:

HP_1 –original horsepower

HP_2 –new horsepower

RPM_1 –original speed

RPM_2 –new speed

$$HP_2 = HP_1 \times (RPM_2/RPM_1)^3$$

$$HP_2 = 5 \times (3000/3500)^3 = 5 \times .630 = 3.15 \text{ horsepower}$$

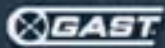

Pressure Varies In Direct Proportion To Altitude

At low altitudes in an indoor environment, the small changes in Regenair® blower performance are usually ignored. At high altitudes, these changes become significant and should not be ignored.

The performance of all regenerative blowers varies directly with changes in air density according to the Fan Laws. These Fan Laws don't apply to our positive displacement pumps. Altitude changes air density as well as air temperature.

All the catalog performance tests for Regenair® blowers were conducted at an altitude of 635 ft. This makes the Regenair® blowers capable of 2% more pressure than the nominal advertising indicates. So in predicting changes in performance we should use the 635 ft. altitude as a starting point.

A 10% decrease in air density reduces pressure performance by 10%. For example: if a blower like the R5 produces 110 CFM at 40 inches of water pressure, with a 10% decrease in air density, it will produce this same air flow at 90% of 40" or 36" of water pressure. The open, no duty flow ratings of any of the blower don't change with air density changes. The maximum rated pressure or vacuum changes the most.

For example, a blower is to operate at an elevation of 5000 feet and is to deliver 60 inches of water pressure gage. What pressure at standard air is required?

Let:

PB – pressure (standard air) blower = 60 inches of water

InH₂O – inches of water pressure

PSL – absolute pressure at sea level, In. Hg. = 29.92 inches Hg.

PA – absolute pressure at altitude, In. Hg. = 24.89 inches Hg. from table for 5000 feet altitude.

$$PB = \text{InH}_2\text{O} \times (\text{PSL}/\text{PA})$$

$$PB = 60 \times (29.92/24.89) = 72 \text{ inches of water at standard conditions}$$

To determine what pressure a 90 inches of water (standard air) blower will deliver at 5000 feet:

Let:

PD – pressure delivered by a 90 inches of water (standard air) blower

$$PD = \text{InH}_2\text{O} \times (\text{PA}/\text{PSL})$$

$$PD = 90 \times (24.89/29.92) = 74.9 \text{ inches of water}$$

Gast offers a program called "REGPER" that calculates changes in performance at 60 Hz. for changes in altitude or air temperature and the effect of operating with both pressure and vacuum on a blower at the same time. This program can be found on Gast's Web Site, www.gastmfg.com; you may also contact your Gast Representative for more information on this program.

Ft. Altitude	In. Hg.	In. H₂O	PSIA
0	29.92	406.73	14.69
500	29.39	399.53	14.43
1000	28.86	392.32	14.17
1500	28.34	385.25	13.91
2000	27.82	378.19	13.66
2500	27.32	371.39	13.41
3000	26.82	364.59	13.17
3500	26.33	357.93	12.93
4000	25.84	351.27	12.69
4500	25.37	344.88	12.46
5000	24.89	338.49	12.23
5500	24.44	332.24	12.00
6000	23.98	325.98	11.77
6500	23.53	319.87	11.55
7000	23.09	313.89	11.34
7500	22.66	308.04	11.13
8000	22.23	302.19	10.91
8500	21.81	296.49	10.71
9000	21.39	290.78	10.50
9500	20.98	285.20	10.30
10000	20.58	279.76	10.10

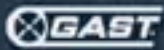

Calculating System Friction Loss

Friction causes pressure loss in all systems. Plumbing design and length affect this loss in air flow.

1. Determine total straight pipe equivalent.

List number of each fitting in system. Circle the column under the supply pipe size. Multiply the number of each item by the pipe size conversion factor to find the equivalent amount of straight pipe. Add equivalent figures to actual straight pipe figures.

Friction loss in pipe fittings equivalent length of straight pipe

Fitting	#	3/4"	1"	1-1/4"	1-1/2"	2"	2-1/2"	3"	4"	5"	Equivalent Ft.
90° Elbows	x	2.0	3.0	3.5	4.0	5.0	6.0	8.0	10.0	12.6	=
Std. through tees	x	1.5	2.0	2.5	3.0	3.5	4.0	5.0	7.0	8.4	=
Std. branch tees	x	4.0	5.0	7.0	8.0	10.5	12.5	15.5	20.0	25.2	=
Check valves	x	7.0	9.0	11.5	13.5	17.0	20.5	25.5	34.0	42.0	=
Gate Valves	x	0.55	0.7	0.9	1.0	1.5	2.0	2.0	3.0	3.4	=

Total length of straight pipe = _____ ft.

Total straight pipe equivalent = _____ ft.

2. Determine total friction loss in pipe system.

On bottom line of the pipe friction loss chart, mark the air flow needed. Using a ruler, scan vertically from the CFM figure to the diagonal line for the proper pipe size. Mark the intersection and then scan to the left (vertical) axis to find the friction loss figure.

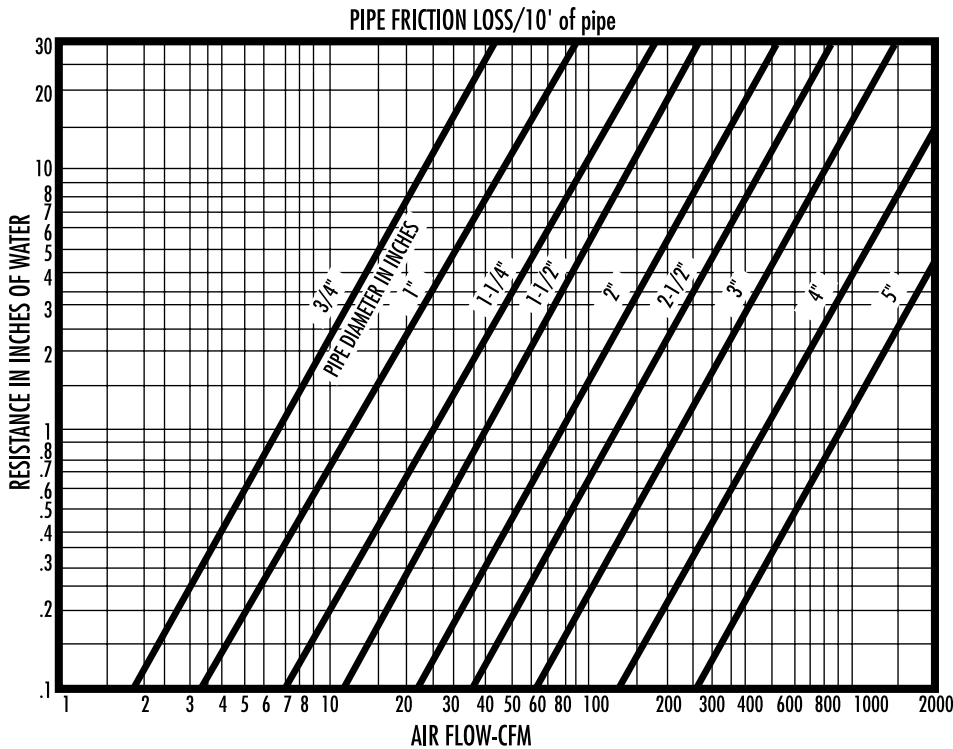

3. Divide the Total straight pipe equivalent from step 1 by 10; multiply by friction loss figure just determined to get the total friction loss in the pipe system.

$$\text{_____} \div 10 \times \text{_____} = \text{_____}$$

Total feet of pipe in system

Friction loss factor

Total friction loss in system in inches of H₂O